







# Hospitality Solutions

Hospitality operations increasingly want products that fit their locale. Forbes' aim is to provide solutions that look right at home, whether home is the Vegas strip, downtown Austin, or a resort in Miami. Every Forbes product is made to order. A multitude of color and finish options make it easy for customers to design something unique.

## **MULTI-FUNCTIONAL SOLUTIONS**

The "back of house" in hotels is getting smaller. Multi-functional products from Forbes help hoteliers perform more with less.

## **SUSTAINABILITY**

Located in Ontario, California, Forbes operates under the strictest environmental regulations in the world. Forbes helps customers meet their sustainability goals through the use of durable and recyclable materials, environmentally safe coatings and long-lasting products.





*Here's to longevity...*

- The Birdcage Luggage Cart pictured above was originally purchased in 2002 (Photographed in 2019) -  
Property: Omni Rancho Las Palmas Resort & Spa

# TABLE OF CONTENTS

<b>Luggage Carts &amp; Bellman's Equipment</b>	05
Birdcage Luggage Carts	06
Luxury Vinyl Deck Options	11
Specialty Luggage Carts	13
Economy Luggage Carts	20
Accessories & Finish Options	24
Self Service Luggage Carts	27
Bellman's Handtrucks	31
<b>Housekeeping Equipment</b>	34
Plastic Housekeeping Carts	36
Steel Housekeeping Carts	38
Specialty Housekeeping Carts	41
InRoom Housekeeping Carts	43
Public Area Carts	48
Accessories & Finish Options	57
Laundry, Linen, & Utility Carts	61
Garment Racks	65

**United States Of America**  
Forbes Industries  
1933 East Locust Street  
Ontario, California 91761  
Phone: 800.832.5427  
Fax: 909.923.1969  
Email: [sales@forbesindustries.com](mailto:sales@forbesindustries.com)  
Web: [www.forbesindustries.com](http://www.forbesindustries.com)

**Asia**  
Forbes Industries Asia  
100 Beach Road #28-05  
Shaw Tower, Singapore 189702  
Phone: 65.6295.2262  
Fax: 65.6295.2022  
Email: [enquiry@forbes-asia.com.sg](mailto:enquiry@forbes-asia.com.sg)  
Web: [www.forbes-asia.com](http://www.forbes-asia.com)



67	<b>Luggage Racks</b>
69	Steel Luggage Racks
71	Wood Luggage Racks
73	<b>Host &amp; Valet Stations</b>
80	<b>Dance Floors</b>
83	Florlok
84	Outlok
86	<b>Public Guidance</b>
87	Classic Stanchions
89	Retractable Beltrac Series
91	<b>Forbes Express</b>

### Finish Options:



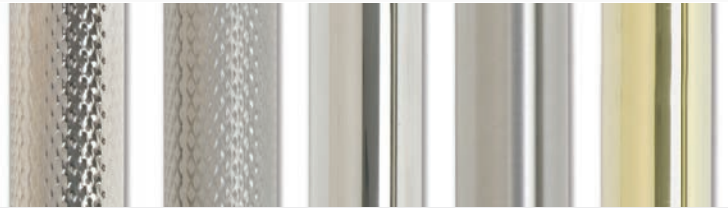



For a complete list of finish options, please visit [www.forbesindustries.com/finish-options](http://www.forbesindustries.com/finish-options)





## HOSPITALITY SOLUTIONS VOL III

© Forbes Industries 2019

Join us on social media for special sneak-peaks and exclusive promotions!

-  [facebook.com/ForbesIndustries](https://facebook.com/ForbesIndustries)
-  [instagram.com/forbesindustries](https://instagram.com/forbesindustries)
-  [twitter.com/forbesindustrie](https://twitter.com/forbesindustrie)
-  [linkedin.com/company/forbes-industries](https://linkedin.com/company/forbes-industries)
-  [youtube.com/user/ForbesIndustries](https://youtube.com/user/ForbesIndustries)
-  [pintrist.com/ForbesIndustries1919](https://pintrist.com/ForbesIndustries1919)

### Icon Legend

-  • Best Sellers/Favorites
-  • Economy
-  • Quick Ship - usually ships in one week or less



# Luggage Carts & Bellman's Equipment

BIRDCAGE | SPECIALTY | ECONOMY | SELF-SERVICE | BELLMAN'S HANDTRUCKS



*When quality matters...*

- The Birdcage Luggage Carts pictured above were originally purchased in 2007 (Photographed in 2019) -  
Property: The Woodlands Waterway Marriott



## BIRDCAGE® LUGGAGE CARTS

Forbes' signature Birdcage® Luggage Cart design is often imitated but never duplicated. It is recognized as a symbol of excellence in upscale accommodations worldwide. With many styles to choose from, it sets the standard for aesthetics and functionality when it comes to high end Luggage Carts. All Birdcage® Luggage Carts feature casters mounted to a steel reinforced carpeted deck with a full wrap-around bumper to protect your quality investment.



Most parts for birdcage carts are designed to be replaceable



Solid Brass or Stainless Steel screws incorporate semipermanent Loctite to secure components and hardware



Welded retaining fingers secure hanging items



Heavy duty hanger bar is constructed from extra thick gauge tube with reinforced welds that offer a high capacity hanger bar



Full wrap-around bumper adds complete perimeter protection



Thick gauge steel mounting plates secure casters and make replacement fast and easy



Reinforced Steel Deck is built with 1" square steel tube and sheet steel. Underside has powder-epoxy painted finish





# LUGGAGE CARTS

BIRDCAGE® LUGGAGE CARTS



## Model 2525-ECH-EN-EN

*2" Polished Stainless Steel tube dipped in Black Chrome with a clear coat finish*

*Full perimeter skirt*

*8" Black pneumatic wheels with black painted hubs*

	Length	Width	Height
in:	43	24	78
cm:	110	61	199

## Model 2525-CEN-EN-EN

*2" Brushed Stainless Steel tube finished in Centurion Black powder-epoxy*

*Full perimeter skirt*

*8" Black pneumatic wheels with black painted hubs*

	Length	Width	Height
in:	43	24	78
cm:	110	61	199





**Model 2526-SS**

*2" Brushed Stainless Steel tube*

*Brushed Stainless Steel skirt*

*8" Gray cushion wheels in chrome plated casters*

	Length	Width	Height
in:	43	24	78
cm:	110	61	199

- \*Model 2526 - Polished Stainless Steel
- \*Model 2526-PDT - Polished Diamond Textured
- \*Model 2526-DT - Diamond Textured
- \*Model 2426 - Polished Brass



**Model 2425**

*2" Polished Brass tube*

*Solid Brass skirt*

*8" Black pneumatic wheels in brass plated casters*

	Length	Width	Height
in:	43	24	78
cm:	110	61	199

- \*Model 2525 - Polished Stainless Steel
- \*Model 2525-SS - Brushed Stainless Steel
- \*Model 2525-PDT - Polished Diamond Textured
- \*Model 2525-DT - Diamond Textured



# LUGGAGE CARTS

BIRDCAGE® LUGGAGE CARTS



## Model 2519

1.5" Polished Stainless Steel tube  
Stainless Steel skirt  
8" Gray cushion wheels in chrome plated casters

	Length	Width	Height
in:	43	24	78
cm:	110	61	199

- \*Model 2519-SS - Brushed Stainless Steel
- \*Model 2519-PDT - Polished Diamond Textured
- \*Model 2519-DT - Diamond Textured
- \*Model 2419 - Polished Brass



## Model 2528-SS

2" Brushed Stainless Steel tube  
Stainless Steel skirt  
8" Black pneumatic wheels in chrome plated casters

	Length	Width	Height
in:	48	24	72
cm:	122	61	183

- \*Model 2528 - Polished Stainless Steel
- \*Model 2528-PDT - Polished Diamond Textured
- \*Model 2528-DT - Diamond Textured
- \*Model 2428 - Polished Brass



## Model 2523

2" Polished Stainless Steel tube  
Two extra horizontal retaining bars  
8" Black pneumatic wheels in chrome plated casters

Extra long deck (48")

Longest & tallest Birdcage® model

	Length	Width	Height
in:	48	24	78
cm:	122	61	199

- \*Model 2523-SS - Brushed Stainless Steel
- \*Model 2523-PDT - Polished Diamond Textured
- \*Model 2523-DT - Diamond Textured
- \*Model 2423 - Polished Brass







### Model 2437

2" Polished Brass tube  
8" Black pneumatic wheels in brass plated casters

	Length	Width	Height
in:	48	24	72
cm:	122	61	183

- \*Model 2537 - Polished Stainless Steel
- \*Model 2537-SS - Brushed Stainless Steel
- \*Model 2537-PDT - Polished Diamond Textured
- \*Model 2537-DT - Diamond Textured

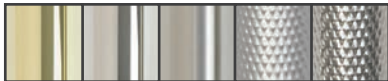

### Model 2521

2" Polished Stainless Steel tube  
8" Black pneumatic wheels in chrome plated casters

	Length	Width	Height
in:	43	24	78
cm:	110	61	199

- \*Model 2521-SS - Brushed Stainless Steel
- \*Model 2521-PDT - Polished Diamond Textured
- \*Model 2521-DT - Diamond Textured
- \*Model 2421 - Polished Brass



### Model 2518

2" Polished Stainless Steel tube  
6" Gray cushion wheels in zinc plated casters

	Length	Width	Height
in:	43	24	78
cm:	110	61	199

- \*Model 2518-SS - Brushed Stainless Steel
- \*Model 2518-PDT - Polished Diamond Textured
- \*Model 2518-DT - Diamond Textured
- \*Model 2418 - Polished Brass



# LUGGAGE CARTS

LUXURY VINYL DECK OPTIONS

## LUXURY VINYL DECK OPTIONS

Luxury vinyl decking material is now available on all skirted Luggage Carts! Step up your Luggage Cart game with six beautiful wood color options that are sure to turn heads and make your equipment stand out from the pack.



Ebony

Aged Redwood

French Oak





AVAILABLE ON ALL SKIRTED LUGGAGE CARTS



Vintage Pine



Country Oak

Bracken



# LUGGAGE CARTS

## SPECIALTY LUGGAGE CARTS

### SPECIALTY LUGGAGE CARTS

Forbes Specialty Luggage Carts are designed to accommodate virtually any need and budget. Forbes has a vast selection of over 50 base models in a variety of sizes, accessories, and color options for you to choose from. Let Forbes help you find your perfect Luggage Cart today. Custom designs available. All Specialty Luggage Carts feature casters mounted to a steel reinforced carpeted deck with a full wrap-around bumper to protect your quality investment.





*Features a reinforced hanger bar*



**Model 2545DB**

*1.5" Polished Stainless Steel square tube*

*"T" hanger bar*

*Dual full wrap-around bumpers*

*Polished Stainless Steel shrouded base*

*6" Gray cushion wheels in chrome plated casters*

	Length	Width	Height
in:	44	25.5	72
cm:	112	65	183

\*Model 2545DB-SS- Brushed Stainless Steel



**Model 2505DB**

*1.5" Polished Stainless Steel square tube*

*"T" hanger bar*

*Dual full wrap-around bumpers*

*Polished Stainless Steel partially shrouded base*

*6" Gray cushion wheels in chrome plated casters*

	Length	Width	Height
in:	44	25.5	72
cm:	112	65	183

\*Model 2505DB-SS - Brushed Stainless Steel



# LUGGAGE CARTS

## SPECIALTY LUGGAGE CARTS

Features a unique X-Frame design



### Model 2581

1.5" Polished Stainless Steel square tube

Hanger bar

8" Black pneumatic wheels in chrome plated casters

	Length	Width	Height
in:	48	23	72
cm:	122	59	183

\*Model 2581-SS - Brushed Stainless Steel



### Model 2510-DT

2" Diamond Textured Stainless Steel tube

Diamond shaped finial

Stainless Steel skirt

8" Black pneumatic wheels in chrome plated casters

	Length	Width	Height
in:	43	24	78
cm:	110	61	199

\*Model 2510 - Polished Stainless Steel

\*Model 2510-SS - Brushed Stainless Steel

\*Model 2510-PDT - Polished Diamond Textured

\*Model 2410 - Polished Brass







**Model 2512-SS**

*2" Brushed Stainless Steel tube*



*Horizontal cross tube with hanger bar*

*8" Black pneumatic wheels in zinc plated casters*

	Length	Width	Height
in:	42.5	24	68
cm:	108	61	173



**Model 2511-SS**

*2" Brushed Stainless Steel tube*



*Enclosed hanger bar*

*8" Black pneumatic wheels in zinc plated casters*

	Length	Width	Height
in:	42.5	24	76
cm:	108	61	194

# LUGGAGE CARTS

## SPECIALTY LUGGAGE CARTS



### Model 2499

*1.25" Brushed Stainless Steel tube*

*Four utility hooks*

*Extra long hanger retainer bars*

*8" Cushion gray wheels in zinc plated casters*

	Length	Width	Height
in:	46.75	23	77.5
cm:	119	59	197

\*Model 2499-DT - Diamond Texture

### Model 2549

*1.25" Polished Stainless Steel tube*

*Four utility hooks*

*8" Gray cushion wheels in chrome plated casters*

	Length	Width	Height
in:	48.5	23.5	75
cm:	124	60	191

\*Model 2549-SS - Brushed Stainless Steel

\*Model 2549-DT - Diamond Texture

\*Model 2549-PDT - Polished Diamond Texture





### Model 2484

*1.25" Brushed Stainless Steel tube*

*Retaining bars*

*8" Gray cushion wheels in zinc plated casters*

	Length	Width	Height
in:	44	23	71.25
cm:	112	59	181



### Model 2543

*1.5" Polished Stainless Steel tube*

*Retaining bars*

*6" Gray cushion wheels in chrome plated casters*

	Length	Width	Height
in:	43.5	22	69.5
cm:	111	56	177

\*Model 2543-SS - Brushed Stainless Steel

\*Model 2543-PDT - Polished Diamond Textured

\*Model 2543-DT - Diamond Texture

\*Model 2443 - Polished Brass



# LUGGAGE CARTS

## SPECIALTY LUGGAGE CARTS



### **Model 2479**

*1.25" Brushed Stainless Steel tube*

*Double hanger bar*

*Retaining bars*

*8" Gray cushion wheels in zinc plated casters*

	Length	Width	Height
in:	37	23	77
cm:	94	59	196

\*MOQ of 5

### **Model 2487**

*1" Brushed Stainless Steel tube*

*Retaining bars*

*8" Black pneumatic wheels in zinc plated casters*

	Length	Width	Height
in:	37	21	71
cm:	94	54	181



**ECONOMY LUGGAGE CARTS**

Forbes' large selection of durable and attractive Economy Luggage Carts are available in a variety of styles and sizes. In addition to several finishes and available bumper and carpet colors, we also offer many accessories to further customize your Luggage Cart to reflect your business's image and impress your guests. Forbes Economy Luggage Carts are also built upon a steel reinforced deck to provide durability and a long-life.



# LUGGAGE CARTS

## ECONOMY LUGGAGE CARTS



### Model 2431

1" Painted steel tube

Full wrap-around bumper

5" Gray wheels

	Length	Width	Height
in:	37	21	63.5
cm:	94	54	162



### Model H1210-8C

1" Chrome plated steel tube



Retaining bars

Full wrap-around bumper

8" Black wheels

	Length	Width	Height
in:	37	18.5	68.5
cm:	94	47	174

\*Model H1210-5C - 5" Gray wheels



### Model 2497

*1.25" Brushed Stainless Steel tube*

*Retaining bars*

*Full wrap-around bumper*

*8" Gray cushion wheels in zinc plated casters*

	Length	Width	Height
in:	48	24	70.5
cm:	122	61	180



### Model 2495

*1" Brushed Stainless Steel tube*



*Full wrap-around bumper*

*8" Black wheels*



	Length	Width	Height
in:	47	22	70.5
cm:	120	56	180



# LUGGAGE CARTS

## ECONOMY LUGGAGE CARTS



### Model H1211-5C

*1" Painted steel tube*

*Retaining bars*

*Carpeted deck*

*Full wrap-around bumper*

*5" Gray wheels*

	Length	Width	Height
in:	35.5	17	65.5
cm:	91	44	167

\*Model H1211-8C- 8" Black wheels



### Model 2434

*1" Painted steel tube*



*Full wrap-around bumper*

*8" Black wheels*



	Length	Width	Height
in:	37	21	66.5
cm:	94	54	169

TUBE FINISH OPTIONS

POLISHED BRASS

BRUSHED STAINLESS STEEL

POLISHED STAINLESS STEEL

DIAMOND TEXTURED STAINLESS STEEL

POLISHED DIAMOND TEXTURED STAINLESS STEEL

\*These finish options are only available on Luggage Carts with 1.25"-2" tube.

Flitz® metal polish is available to keep your Luggage Carts looking shiny and new! Call us today for more details.





# LUGGAGE CARTS

## LUGGAGE CART ACCESSORIES

### LOGO FINIALS

Forbes can customize your logo onto our finials! Logo finials are available in Polished Brass, Mirrored or Brushed Chrome. On engraved finials, recessed areas of the logo are painted black to enhance the design. Custom shaped logos are also available. Please call for more information.

**Engraved Brass**  
Polished



**Engraved Chrome**  
Brushed



Polished

**Silk-screened**  
Polished



### LUGGAGE CART COVERS

#### Stretch Covers

Stretch covers available for Birdcage® Luggage Carts in all sizes. Color and logo options are available. Call for information and pricing.



#### Nylon Covers

Nylon covers are available for all Forbes Luggage Carts. Standard color is Taupe (other colors available.) Shown with optional custom logo. Please call for information and pricing.



### DECK OPTIONS

#### Rubberized Deck

Durable and decorative black rubberized material can be fitted to any skirted cart in place of carpet as an upgrade. Please call for information and pricing.



#### Logo Carpets

Forbes can customize any carpeted Luggage Cart deck to display your company logo.



### SHELF OPTIONS



**Model 2400-4Shelf**  
4-sided carpeted shelf designed to fit Forbes Luggage Carts. Please specify cart model at time of order.



**Model 2400-Shelf**  
Removable carpeted shelf designed to fit Forbes Luggage Carts. Please specify cart model at time of order.

### MISCELLANEOUS

#### Vertical Bars



**Model 240**  
Solid Brass vertical retaining bar for Birdcage® Luggage Carts.

**Model 250**  
Stainless Steel vertical retaining bar for Birdcage® Luggage Carts.

#### Push Bar Covers



**Model 2400-VCVR**  
Carpet Push Covers designed to fit Forbes vertical uprights above push bars on 2" diameter tube Luggage Carts.

**Model 2400-HCVR**  
Carpet Push Covers designed to fit Forbes horizontal push bars on 2" diameter tube Luggage Carts.

#### Nylon End Covers



Available in several colors. Shown with custom logo. Please call for more information and pricing.

**CARPET COLOR OPTIONS**



**BUMPER COLOR OPTIONS**

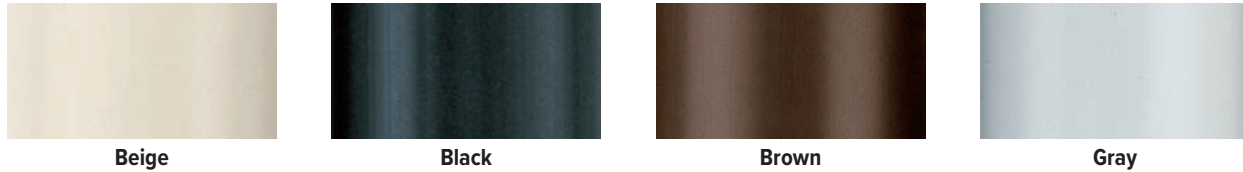

**PAINT COLOR OPTIONS FOR PAINTED CARTS**

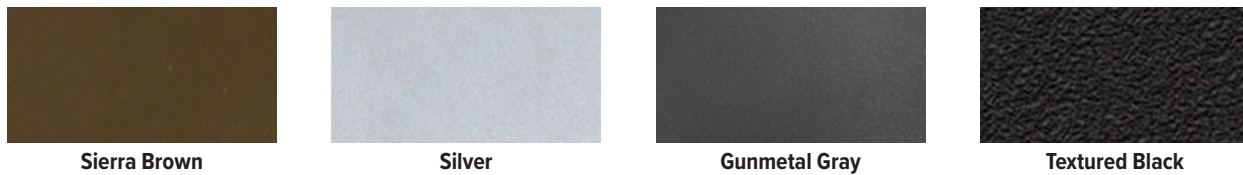

**WHEEL AND BRAKE OPTIONS**

	<b>Wheel Size/Tread</b>	<b>Wheel Only</b>	<b>Wheel Assembly w/ Brake Kit</b>	<b>Rigid Caster w/ Wheel</b>	<b>Swivel Caster w/ Wheel</b>
	5" Gray	N/A	1616-S/BK (Zinc)	1616-R (Zinc)	1616-S (Zinc)
	8" Black	1632-W	1632-S/BK (Zinc)	1632-R (Zinc)	1632-S (Zinc)
	8" Gray	1634-W	1634-S/BK (Zinc)	1634-R (Zinc)	1634-S (Zinc)
	5" Gray	N/A	6050-S/BK (Brass) 6050-SC/BKC (Chrome)	6050-R (Brass) 6050-RC (Chrome)	6050-S (Brass) 6050-SC (Chrome)
	6" Cushion Gray	1626-W (Aluminum hub)	1626-S/BK (Zinc) 1626-SB/BKB (Brass) 1626-SC/BKC (Chrome)	1626-R (Zinc) 1626-RB (Brass) 1626-RC (Chrome)	1626-S (Zinc) 1626-SB (Brass) 1626-SC (Chrome)
	8" Black Pneumatic	1635-W (Zinc) 1635-WB (Brass) 1635-WC (Chrome)	1635-S/BK (Zinc) 1635-SB/BKB (Brass) 1635-SC/BKC (Chrome)	1635-R (Zinc) 1635-RB (Brass) 1635-RC (Chrome)	1635-S (Zinc) 1635-SB (Brass) 1635-SC (Chrome)
	8" Black Flat-Free	1636-W (Zinc) 1636-WB (Brass) 1636-WC (Chrome)	N/A	1636-R (Zinc) 1636-RB (Brass) 1636-RC (Chrome)	1636-S (Zinc) 1636-SB (Brass) 1636-SC (Chrome)
	8" Cushion Grey	1641-W (Aluminum hub)	1641-S/BK (Zinc) 1641-SB/BKB (Brass) 1641-SC/BKC (Chrome)	1641-R (Zinc) 1641-RB (Brass) 1641-RC (Chrome)	1641-S (Zinc) 1641-SB (Brass) 1641-SC (Chrome)

# LUGGAGE CARTS

## SELF SERVICE LUGGAGE CARTS

### STANDARD SELF SERVICE LUGGAGE CARTS

Forbes' large selection of durable and attractive Self-Service Luggage Carts are available in a variety of styles and sizes. Forbes offers many accessories to further customize your Luggage Cart to reflect your business' image and impress your guests.

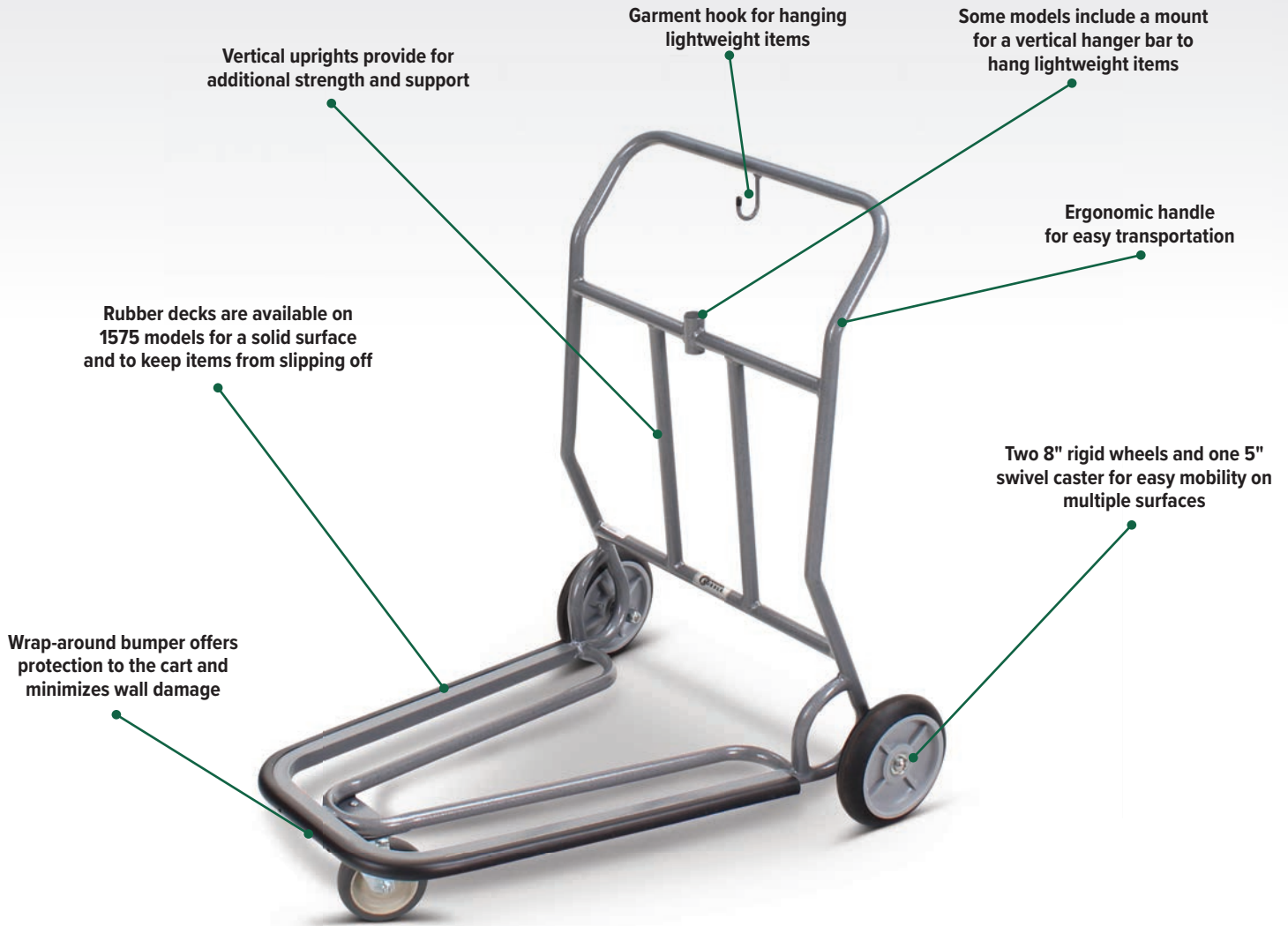

Baskets and custom logo plates are available for property branding

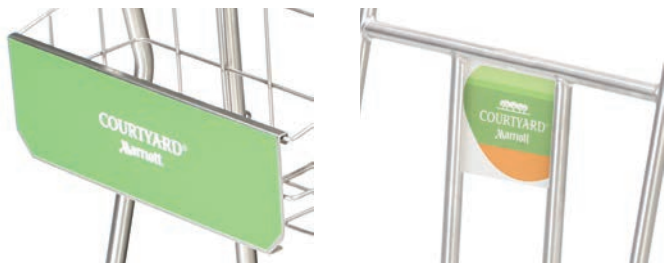

1574 Models (without rubber deck) are nestable for compact storage



Low-profile bolt head to protect walls from being damaged









**NESTABLE!**



**NESTABLE!**





-  **Model 1574-SS-HB**  
34.75"H garment hanger bar
-  **Brushed Stainless Steel round tube frame**
- Two vertical retainer bars**
- Vinyl bumper**
- Two 8" wheels & one 5" swivel wheel**

	Depth	Width	Height
in:	37	28	71.25
cm:	94	72	181

-  **Model 1574**  
Round tube steel frame finished in Silver  
Hammertone powder-epoxy paint
- Two vertical retainer bars**
- Vinyl bumper**
- Two 8" wheels & one 5" swivel wheel**

	Depth	Width	Height
in:	37	28	37
cm:	94	72	94

\*Model 1574-HB - Powder-epoxy painted with hanger bar

-  **Model 1575-SS**  
Brushed Stainless Steel round tube frame
-  **Two vertical retainer bars**
- Rubber deck**
- Vinyl bumper**
- Two 8" wheels & one 5" swivel wheel**

	Depth	Width	Height
in:	37	28	37
cm:	94	72	94

\*Model 1575 - Powder-epoxy painted  
\*Model 1575-HB - Powder-epoxy painted frame with rubber deck  
\*Model 1575-SS-HB - Brushed Stainless Steel frame with rubber deck

## FINISHES

### POWDER-EPOXY PAINT OPTIONS

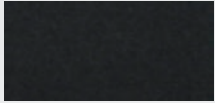

Textured Black

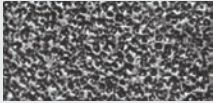

Silver Hammertone

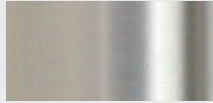

Brushed Stainless Steel

### RUBBER DECK OPTIONS



Jet Black

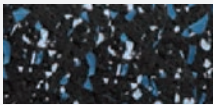

Devil Blue

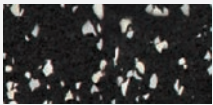

Whirlwind White



## ACCESSORIES



#### Custom Logos

Color logo for 1574/1575 self-service Luggage Carts, two per cart (front and back)



#### Custom Logos

Color logo for 1574/1575 self-service Luggage Carts, two per cart (front and back)



#### Model 1574-BSKT

Black vinyl-dipped (for noise reduction) wire basket for self-service Luggage Carts

\*Model 1575-BSKT - Basket for model 1575



#### Hanger Bar

Vertical hanger bar to hang lightweight items

**KNOCKED-DOWN SELF SERVICE LUGGAGE CARTS**



ALL 1573 MODELS ARE NESTABLE AND SHIP "KNOCKED-DOWN" SAVING YOU SIGNIFICANT MONEY ON SHIPPING AND CAN ALSO BE SHIPPED VIA UPS, FEDEX, AND MOST OTHER STANDARD PARCEL CARRIERS!

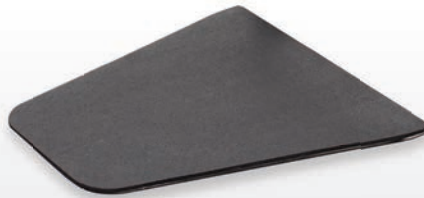

\*1573-DECK - Add the optional removable deck platform to any 1573 model. Clips on in seconds for additional surface area.



**Model 1573-SS**

- Brushed Stainless Steel round tube frame*
- Two vertical retainer bars*
- Optional rubber deck accessory available*
- Vinyl bumper*
- Two 8" wheels & one 5" swivel wheel*
- Ships "KD" and frame is assembled in minutes with 4 bolts*

	Depth	Width	Height
in:	37	28	37
cm:	94	72	94

\*Model 1573 - Powder-epoxy painted



**Model 1573-SS-HB**

- Brushed Stainless Steel round tube frame*
- Two vertical retainer bars*
- Optional rubber deck accessory available*
- Vinyl bumper*
- Two 8" wheels & one 5" swivel wheel*
- Ships "KD" and frame is assembled in minutes with 4 bolts*

	Depth	Width	Height
in:	37	28	37
cm:	94	72	94

\*Model 1573-HB - Powder-epoxy painted with hanger bar



# LUGGAGE CARTS

BELLMAN'S HANDTRUCKS

## BELLMAN'S HANDTRUCKS

Forbes Handtrucks are made with the highest quality materials so that they can perform in the toughest of situations. Custom designs available.



### Model 1570-CK-PS

1" Polished Stainless Steel tube  
"Hoop Leg Design" with rubber feet  
10" Black pneumatic wheels  
23.5"L (59 cm) Drop-nose

	Width	Height
in:	22	47
cm:	56	120

\*Model 1570-CK-SS - Brushed Stainless Steel

\*Model 1570-CK - Brushed Brass



### Model 1550-CK

1" Brushed Stainless Steel tube  
Carpet kit  
10" Black zero-pressure wheels  
24"L (61 cm) Drop-nose

	Width	Height
in:	19	45.5
cm:	49	116

### Model 1552-CK

1" Brushed Stainless Steel tube  
Carpet kit  
10" Black pneumatic wheels  
24"L (61 cm) Drop-nose

	Width	Height
in:	21.5	45.5
cm:	55	116



**Model 1555-CK**

*1" Brushed Brass tube*

*Carpet kit*

*10" Black pneumatic wheels*

*23.5"L (59 cm) Drop-nose*

	Width	Height
in:	22	46
cm:	56	117

**Model 1555-CK-PS**

*1" Polished Stainless Steel tube*

*Carpet kit*

*10" Black pneumatic wheels*

*23.5"L (59 cm) Drop-nose*

	Width	Height
in:	22	46
cm:	56	117

\*Model 1555-CK-SS - Brushed Stainless Steel

**Model 1566-CK-PS**

*1" Polished Stainless Steel tube*

*Carpet kit*

*Back plate*

*10" Black pneumatic wheels*

*29"L (74 cm) Drop-nose*

	Width	Height
in:	22	49.5
cm:	56	126

\*Model 1566-CK-SS - Brushed Stainless Steel

\*Model 1566-CK - Brushed Brass

# LUGGAGE CARTS

## BELLMAN'S HANDTRUCKS



### Model 1555-B-PS

1" Polished Stainless Steel tube

Bumpered (black)

10" Black pneumatic wheels

23.5"L (59 cm) Drop-nose

	Width	Height
in:	22	46
cm:	56	117

\*Model 1555-B - Brushed Brass

\*Model 1555-B-SS - Brushed Stainless Steel



### Model 1570-B-SS

1" Brushed Stainless Steel tube

Bumpered (brown)

"Hoop-leg" design with rubber feet

10" Black pneumatic wheels

23.5"L (59 cm) Drop-nose

	Width	Height
in:	22	47
cm:	56	119

\*Model 1570-B - Brushed Brass

### Model 1570-B-PS

1" Polished Stainless Steel tube

Bumpered (brown)

"Hoop-leg" design with rubber feet

10" Black pneumatic wheels

23.5"L (59 cm) Drop-nose

	Width	Height
in:	22	47
cm:	56	119



# Housekeeping Equipment

PLASTIC | STEEL | SPECIALTY | PUBLIC AREA  
INROOM | ACCESSORIES | LAUNDRY, LINEN, & UTILITY | GARMENT RACKS



# HOUSEKEEPING EQUIPMENT

## HOUSEKEEPING CARTS

### FORBES HOUSEKEEPING CARTS

The innovative modular design behind Forbes Industries' housekeeping carts makes them easier to assemble, to use, to upgrade and to customize. Basic design consists of two handles, plastic or steel cabinet, two end platforms and four casters. Pick from any of our standard models or choose from our many accessories to design a custom Forbes cart that fits your operation.



Several types of top tray organizers are available to keep amenities separated and where they belong

Privacy panels are available and designed to shield the public's view as well as discourage the overloading of housekeeping supplies

Bag lids are available to keep soiled linens or trash out of the public's view

Handles are available in low profile, ergonomic, single and double bag styles

Several bag sizes, materials, colors, and zipper options are available

Our housekeeping carts with all welded steel cabinets offer superior durability, are double welded at key stress points, and come in a baked on powder coated finish

Housekeeping carts with ABS plastic cabinets reduce weight without compromising durability; reduce noise during operation; and won't dent, scratch, or rust

Full wrap-around bumper and revolving corner bumpers add protection to your properties, doors and hallway walls

Thick gauge steel mounting plates secure casters and make replacement fast and easy

Most carts allow for the addition of various under-deck accessories for a more personalized fit to help keep your operation running at its peak performance

Reinforced Steel Deck is built with 1" square steel tube and sheet steel and has reinforced steel cross braces. Decks are finished in a durable powder-epoxy paint

All casters are independently mounted to the base which makes caster replacement a breeze. Our unique mounting design allows for the widest possible wheel track which enhances stability and safety

### PLASTIC CARTS

Forbes' Plastic Housekeeping Carts are lightweight and have an extensive line of accessories available to fit your needs. With several different base models to choose from, we are confident that we have the perfect cart for your operation and budget. Forbes is your ultimate Housekeeping Cart source. Bags are sold separately. Call for more information.



#### Model 2192-36

*Cabinet size: 30"W x 36"H*

*Full wrap-around bumper*

*8" Black wheels*

	Length	Width	Height
in:	57	20.5	47
cm:	145	53	120



#### Model 2220

*Cabinet size: 30"W x 36"H*

*Open top tray organizer with curved privacy panel*

*Two brushed stainless steel low-profile handles*

*Under-deck glass rack holder*

*Full wrap-around bumper*

*Corner bumpers*

*Vacuum bracket*

*8" Black wheels*

	Length	Width	Height
in:	56.25	20.5	52.5
cm:	143	53	134

\*Model 2120 - Steel version



# HOUSEKEEPING EQUIPMENT

## PLASTIC CARTS



### Model 2200-38

*Cabinet size: 30"W x 38"H*

*Amenity drawer*

*Under-deck glass rack holder*

*Full wrap-around bumper*

*Corner bumpers*

*Vacuum bracket*

*8" Gray wheels*

	Length	Width	Height
in:	57	20.5	49
cm:	145	53	125



### Model 2193-36

*Cabinet size: 30"W x 36"H*



*Full wrap-around bumper*

*8" Black wheels*

	Length	Width	Height
in:	57	20.5	47
cm:	145	53	120

### STEEL HOUSEKEEPING CARTS

Forbes Steel Housekeeping Carts are available in over 30 different base models giving you many different sizes, designs, and color options to suit virtually any operation. Customize with our extensive line of accessories or let us know your requirements and our product development team will design a custom solution just for you. Bags are sold separately. Call for more information.



#### Model 2107

- Cabinet size: 30"W x 36"H
- Under-deck glass rack holder
- Full wrap-around bumper
- Corner bumpers
- Vacuum bracket
- 8" Gray wheels

	Length	Width	Height
in:	57	20.5	47
cm:	145	53	120

#### Model 2148

- Cabinet size: 30"W x 36"H
- Open top tray organizer
- Under-deck glass rack holder
- Full wrap-around bumper
- Corner bumpers
- Vacuum bracket
- 8" Gray wheels

	Length	Width	Height
in:	57	20.5	54
cm:	145	53	137

#### Model 2101

- Cabinet size: 30"W x 30"H
- Full wrap-around bumper
- 8" Black wheels

	Length	Width	Height
in:	57	20.5	41
cm:	145	53	105

# HOUSEKEEPING EQUIPMENT

## STEEL CARTS



### Model 2150

*Cabinet size: 30"W x 36"H*  
*6" Deep brushed stainless steel top tray organizer*  
*Two adjustable shelves*  
*Vinyl deck mats*  
*Full wrap-around bumper*  
*Corner bumpers*  
*8" Gray wheels*

	Length	Width	Height
in:	57	20.5	47
cm:	145	53	120



### Model 2104

*Cabinet size: 30"W x 36"H*  
*2.5" deep top tray*  
*Full wrap-around bumper*  
*8" Black wheels*

	Length	Width	Height
in:	57	20.5	47
cm:	145	53	120



### Model 2105

*Cabinet size: 30"W x 36"H*  
*Three-bag style*  
*Full wrap-around bumper*  
*8" Black wheels*

	Length	Width	Height
in:	61	20.5	47
cm:	155	53	120



### COMPACT STEEL HOUSEKEEPING CARTS



#### Model 2140

Cabinet size: 18"W x 36"H



Full wrap-around bumper

5" Gray wheels

	Length	Width	Height
in:	45	22	43
cm:	115	56	110



#### Model 2110

Cabinet size: 18"W x 42"H

Tissue and toilet paper roll dispensers

Two-bag style

Three fixed shelves

Under-deck half glass rack holder

Full wrap-around bumper

Corner bumpers

Vacuum bracket

8" Black wheels

	Length	Width	Height
in:	38	22	52.25
cm:	92	56	133



#### Model 2141

Cabinet size: 18"W x 36"H

Dual bag low-profile handle

Three shelves (two adjustable)

Under-deck half glass rack holder

Full wrap-around bumper

Vacuum bracket

8" Black wheels

	Length	Width	Height
in:	37	22	46
cm:	94	56	117

# HOUSEKEEPING EQUIPMENT

## SPECIALTY CARTS

### SPECIALTY HOUSEKEEPING CARTS

With a net weight of only 84 lbs, this full size steel cart offers all the features of the leading competitor's plastic cart and is much **EASIER TO PUSH**. If that isn't enough, Forbes durability and longevity of steel construction are built to stay in operation long after other competitors' carts are retired.

- UP TO 40% EASIER TO PUSH
  - OVER 10% LIGHTER
  - LASTS UP TO 3X LONGER
- THAN THE LEADING COMPETITOR'S CART**



#### Model 2103

*Steel cabinet: 30"W x 19"D x 36"H*



*Textured black powder-epoxy finish*

*2.5" Deep top tray*



*Two low profile handles*

*One 20-NL long nylon bag (black) included*

*Two shelves (one adjustable)*

*Two end platforms with steel square tube*

*Four revolving corner bumpers*

*Under-deck glass rack holder*

*Vacuum bracket*

*8" Black wheels in zinc plated casters*

	Length	Width	Height
in:	54.75	19	46.75
cm:	139	49	119





### MYTHBUSTER HOUSEKEEPING CART

After rumors were circulated that Forbes Industries' Housekeeping Carts were harder to push than a competitor's brand, an independent study was done to put the issue to rest. The study found that not only are Forbes' significantly easier to push, but they are also lighter and last longer than the leading competitor's carts.

#### INITIAL PURCHASE PRICE

LEADING PLASTIC CART



FORBES METAL CART



The initial purchase price of both a Forbes Metal Housekeeping Cart and the leading plastic cart are comparable.

#### PRODUCT WEIGHT

LEADING PLASTIC CART



94lbs

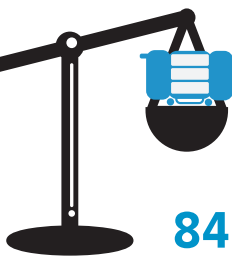

FORBES METAL CART



84lbs

Forbes Industries' metal carts are over 10% lighter than the leading competitor's plastic carts.

#### PRODUCT LONGEVITY

LEADING PLASTIC CART



FORBES METAL CART

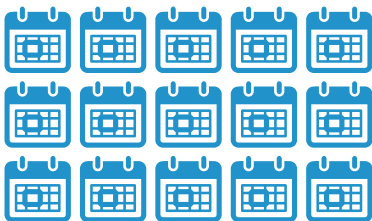

Evidence shows that the average lifespan of a Forbes Metal Housekeeping Cart is 3 times longer than that of the leading plastic cart.

#### EASE OF PUSH STUDY COMPARISON

LEADING PLASTIC CART



FORBES METAL CART



The independent push study showed that the Forbes Industries Metal Cart was up to 40% easier to push than the competitor's plastic housekeeping cart.



# HOUSEKEEPING EQUIPMENT

## SPECIALTY CARTS

### INROOM SERIES

Cluttered corridors? Dirty linens on display to the public? These are things of the past with the new Forbes InRoom Housekeeping Carts. Our unique InRoom carts are designed to allow housekeepers to easily navigate their supplies out of hallways and into guest rooms, effectively decreasing corridor clutter, pilferage, and worker's compensation claims while increasing safety, efficiency, and ROI.

*Watch the video at: [www.forbesindustries.com/inroom-housekeeping-carts](http://www.forbesindustries.com/inroom-housekeeping-carts)*

#### Safety, Security, & Efficiency

By bringing the cart closer to the work area, we have helped **reduce worker fatigue** and **worker's compensation claims**. It just makes sense to keep the tools for the job near at hand so that one is not wasting time and energy trekking back and forth. With the **carts in the room** and the door locked, guest's valuables are **secure** and the housekeeper is **safe**. This will also reduce, if not **eliminate, pilferage** of items from the cart by passing guests and employees.

#### Time is money: Immediate ROI

Protecting your employees from straining and injuring themselves while pushing around a cart that weighs twice what they do is an **ROI** that pays dividends far into the **future**. The Forbes InRoom carts are shorter in length than traditional carts and are available in molded plastic, **greatly reducing** their overall **size** and **weight**. Protecting your walls, door jambs and furniture from damage is an **ROI** you can **realize immediately**. The four revolving corner bumpers and full perimeter fixed vinyl bumper provide **dual protection** for your **walls, entryways, furniture, and fixtures**.

#### Clear hallways = Satisfied guests

Forbes' new InRoom Housekeeping Carts virtually **eliminate guest exposure** to used linens, cleaning supplies, and unsanitary conditions. Guests will greatly appreciate the **clean corridors**, free of housekeeping carts and operations. This will result in an enhanced guest experience which can lead to more **guest referrals** through Internet reviews and social media channels, and more **repeat guests** in the future.

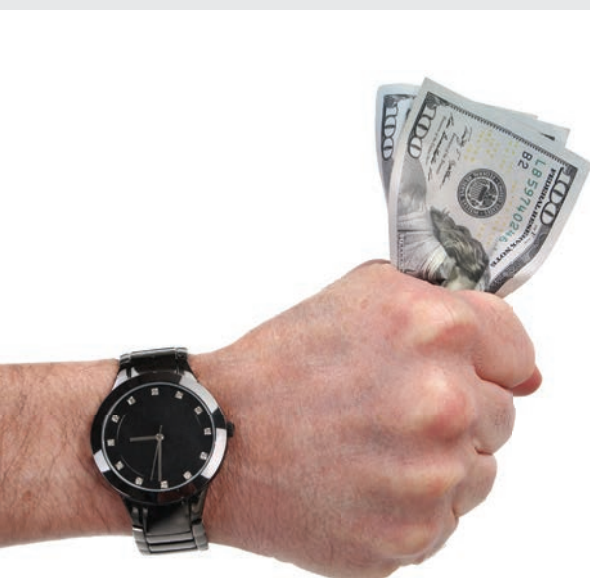

# INROOM Series

## FOOT TRAFFIC COMPARISON



# Alumunique



### Model 2044

*Lightweight aluminum cabinet*

*Ergonomically designed handle*



*Top tray organizer with hinged lid*

*Heavy gauge steel tube vinyl dipped frame*

*Snap-on magnetic front flap*

*Snap-on amenity caddy*

*Two fixed shelves*

*Four swivel wheels*

	Length	Width	Height
in:	22	21	38.75
cm:	56	54	99



\*Built-in top tray organizer



THE  
*Mini-Rollen*  
— HOUSEKEEPING —  
CART  
*durable - lightweight - elegant*



\*Two divided caddies and laundry bag included





\*Divided caddy included



\*Model 2088-LB - Order Separately





**Model 2087 (COMPACT)**

- Compact design*
- Made with heavy duty nylon material*
-  *Retractable aluminum handle*
- Two removable & stackable amenity caddies*
-  *One laundry bag - collapsible*
- Nine storage pockets*
- Reinforced sewn edges*
- Built-in literature storage*
- Four swivel wheels*
- Six-month warranty*

	Length	Width	Height
in:	14.5	16	21
cm:	37	41	54



**Model 2088 (FULL-SIZE)**

- Large capacity storage section*
- Made with heavy duty nylon material*
-  *Retractable aluminum handle*
- Removable & stackable amenity caddy*
-  *Eight storage pockets*
- Reinforced sewn edges*
-  *Built-in literature storage*
- Four swivel wheels*
- Six-month warranty*

	Length	Width	Height
in:	20	16	28.75
cm:	51	41	73

\*Model 2088-LB - Optional collapsible laundry bag

# HOUSEKEEPING EQUIPMENT

## SPECIALTY CARTS



### Model 2261

Steel cabinet - 18"W x 18"D x 36"H

Three shelves

Two-bag style

Full wrap-around bumper

Revolving corner bumpers

6" Raised wheels (swivel with swivel lock)

	Length	Width	Height
in:	38	22	46
cm:	97	56	117

\*Model 2271 - Plastic version



### Model 2265

Steel cabinet - 24"W x 18"D x 42"H

Three shelves



Two-bag style

Amenity drawer

Under-deck half glass rack holder

Full wrap-around bumper

Revolving corner bumpers

6" Raised wheels (swivel with swivel lock)

	Length	Width	Height
in:	44	22	52.25
cm:	112	56	133

\*Model 2275 - Plastic version

### PUBLIC AREA CARTS

Forbes Public Area carts are disguised as elegant pieces of furniture that are designed to take care of the dirty work. They are available in a variety of finishes to suit your needs. Customization is also available to fit your operational needs.



\*Specify one of the following laminate trim finish options when ordering.  
Brass / Chrome / Brushed Chrome

#### Model 2238

*H.P.L. Cabinet*

*Shown with brushed chrome laminate trim  
(Also available in polished chrome and brass)  
Main compartment has one adjustable shelf  
and a trash can*

*Sliding door*

*Sliding lids*

*6" Cushion gray wheels*

	Length	Width	Height
in:	36	23	37
cm:	92	59	94



#### Model 2244

*Wood veneer cabinet*

*Shown with polished chrome laminate trim  
(Also available in brushed chrome and brass)  
Main compartment has one adjustable shelf  
and a trash can*

*Sliding door*

*Sliding lids*

*6" Cushion gray wheels*

	Length	Width	Height
in:	36	23	37
cm:	92	59	94



# HOUSEKEEPING EQUIPMENT

## SPECIALTY CARTS

### ALUMUNIQUE CART

Forbes Alumunique Housekeeping Carts offer a modern look to your everyday Housekeeping Cart. They are durable and lightweight and can be personalized to fit any decor. Let Forbes design your ideal Housekeeping Cart today.

*Lightweight aluminum  
body construction*



*1" Square  
aluminum frame*



*Unique rounded handle  
and end platforms*



# Alumunique

#### **Model 2010**

*Lightweight aluminum construction*

*1" square aluminum frame*

*6.5" deep top tray with privacy panel*

*Three shelf aluminum cabinet*

*Rounded handles and end platforms*

*Two H.D. poly vinyl bags (#26-E)*

*(bags sold separately)*

*8" Black wheels*

	Length	Width	Height
in:	62	21.5	54.75
cm:	158	55	140

**ROTO-MOLDED CART**

The Ultra 2000 features a large interior; roto-molded body is rust-proof, durable, and color-fast. It comes with vertical push handles, two adjustable shelves, and is available with either 8" or 10" casters.

**ULTRA  
2000**

**Model 2339**  
Tambour door lock



**Model 2324-2000**  
4" deep amenity drawer



**Model 2338**  
Combination corner bumpers and  
under-deck vacuum bracket



**Model 2337**  
Corner bumpers



\*Available in Black, Beige, or Gray  
\*Black shown with 10" wheels



**Model 18-NL**  
H.D. brown nylon bag, snap-flap style  
10"D x 21"W x 34"L



**Model 18-CV**  
H.D. canvas bag, snap-flap style  
13"D x 20"W x 32"L



**Model 2000-8**  
Roto-molded polyethylene cabinet  
Plastic tambour door

Two 3-sided bag sections  
Three shelves (two adjustable)

8" Gray wheels

	Length	Width	Height
in:	61	22.5	50
cm:	155	58	127

\*Shown with optional accessories:  
2324-2000 amenity drawer and  
18-CV H.D. canvas bags, order separately.  
\*Model 2000-10: 10" wheel version

# HOUSEKEEPING CARTS

SPECIALTY CARTS

## THE CONTEMPORARY COLLECTION

# EVO



REV 06.22.2020



Removable and adjustable top tray organizer



Modern curved brushed stainless steel corners



Retractable vacuum bracket



Full wrap-around bumper and four revolving corner bumpers



6" Tracking casters assist with InRoom access



Amenity drawer



Two vertical ergonomically designed handles



Built-in flip-out bottle caddy



### Bag Options

**50-NL-E (Bag) - 18"L x 16"W x 33"H**  
 Loop & snap style / Black nylon  
 One bag per cabinet (2277/2279)

**51-NL-E (Bag) - 18"L x 8"W x 33"H**  
 Loop & snap style / Black nylon  
 Two bags per cabinet (2277/2279)



### Model 2277

Cabinet size: 24"W x 19"D x 40"H

Three shelves



Enclosed double bag end with bag lid

Stainless steel handles

Amenity drawer

Bottle caddy flip-out compartment

Full wrap-around bumper

Corner bumpers

Retractable vacuum bracket

6" Raised wheels (swivel with swivel lock)

	Length	Width	Height
in:	45	21.5	53
cm:	115	55	135

\*Model 2279 (Large cabinet version 30"W x 19"D x 40"H)

HOUSEKEEPING CARTS

SPECIALTY CARTS

THE CONTEMPORARY COLLECTION

# CRUISER





Lidded top tray with lid stays



Optional adjustable top tray organizer

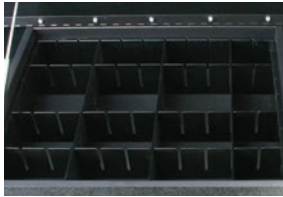

Ergonomically designed vertical push handles



Optional retractable vacuum bracket



6" Tracking casters assist with InRoom access and allow for optional under-deck accessories



Full wrap-around bumper and four revolving corner bumpers



### Model 2280

Plastic cabinet size: 24"W x 19"D x 36.25"H

Brushed stainless steel corner accents

Three fixed shelves

Full size bag handle

Stainless steel vertical push handles

Full wrap-around bumper

Corner bumpers

Optional retractable vacuum bracket

2" Risers to allow under-deck accessories

6" Tracking casters (swivel with swivel lock)

	Length	Width	Height
in:	42.5	21.5	46.5
cm:	108	55	119



HOUSEKEEPING CARTS

SPECIALTY CARTS

THE CONTEMPORARY COLLECTION

# OVERLANDER



REV 06.22.2020

Vertical and horizontal ergonomic handle options



Customizable broom holder



Custom back bumper



Vacuum bracket and removable liner



Two pull-out drawers, one pull-out shelf, and one pull-out tray



Brushed stainless steel bottle caddies



Flat-free pneumatic wheels rollover thresholds with ease



### Model 2281

Steel cabinet: 31"W x 20"D x 41"H

Two vertical push handles slanted at 15°

One horizontal stub handle

Brushed stainless steel corner accents

Brushed stainless steel bottle caddies

Two amenity drawers

One fixed shelf in base cabinet w/ deck mat

Pull-out shelf at base of cabinet

Customizable broom handle holder

Vacuum bracket with eyelet for bungee cord

Custom back bumper

Four flat-free pneumatic wheels

	Length	Width	Height
in:	40	24	51.5
cm:	102	61	131

# HOUSEKEEPING EQUIPMENT

## ACCESSORIES

### STATIONARY ORGANIZERS



**Model 2352**  
Three slots



**Model 2355**  
Five slots



**Model 2357**  
Seven slots

### BAG LIDS



**Model 2336**  
Steel bag lid



**Model 2336-P**  
Plastic bag lid

### AMENITY CADDIES



**Model 2321**  
H.D. Nylon



**Model 2322**  
H.D. Nylon



**Model 2323**  
H.D. Canvas

### DECK MAT



**Model 1401**  
Ribbed vinyl deck mat for steel carts only

### MOP/BROOM CLIP



**Model 2366**  
Spring steel clips secure mop and broom handles

### GLASS RACK



**Model 2331-B**  
Vinyl dipped glass rack

### UTILITY BASKETS



**Model 2320**  
Aluminum utility basket



**Model 2320-B**  
Aluminum utility basket with bumpered base

### DRAWERS



**Model 2324**  
Metal amenity drawer 4" deep



**Model 2325**  
Plastic amenity drawer 4" deep

### UNDER-DECK ACCESSORIES



**Model 2326**  
Under-deck amenity drawer



**Model 2329**  
Vacuum bracket



**Model 2327**  
Under-deck enclosed metal drawer



**Model 2330**  
Under-deck glass rack holder

## TOP TRAY ORGANIZERS



**Model 2351-P**  
Open plastic top tray organizer.  
Metal version - #2351



**Model 2334**  
Open metal top tray organizer.  
Plastic version - #2334-P



**Model 2356**  
Metal top tray organizer with locking lid. Plastic version - #2356-P



**Model 2353-P**  
Open plastic top tray organizer without dividers.  
Metal version - #2353



**Model 2360**  
Metal open top tray organizer with curved privacy panel.  
Metal version for plastic carts - #2360-M

## CART ID TAGS AND AD PANELS



**Cart identification Tags**  
Keep better track of your fleet with cart ID tags.  
Call for more information.



**Ad Panels**  
Help you maximize your property's ROI by giving your guests information on lobby happy hours, restaurant specials and hotel special events.  
Call for more information.

## DOORS



**Doors are available on custom units**  
Lock up amenities and keep items safe with lockable doors. Call for more information.



## BUMPERS



**Model 2337**  
Corner bumpers, factory installed



**Model 1603-BE**  
Corner bumpers, field fit kit.  
(For Gray order 1603-GY)



**Back Bumper**  
Vinyl back bumper, call for more information.



# HOUSEKEEPING EQUIPMENT

## BAG OPTIONS

### LOOP & SNAP STYLE (12"D X 18"W)



### FOLD-OVER-TOP STYLE



### ZIPPER OPTIONS



U-shaped zippers are available on all bags. Call for more information.



**U-Style Zipper**  
Folds up from bottom to top



**A-Style Zipper**  
Folds down from top to bottom

### PAINT COLOR OPTIONS



TEXTURED  
BLACK

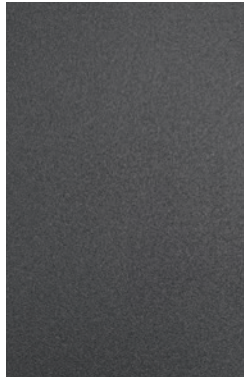

GUNMETAL  
GRAY



SILVER

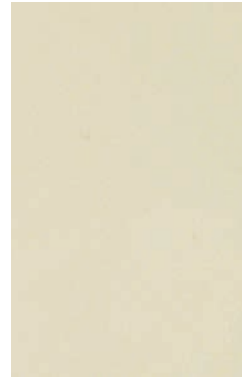

BEIGE



SIERRA  
BROWN

### PLASTIC COLOR OPTIONS



BEIGE

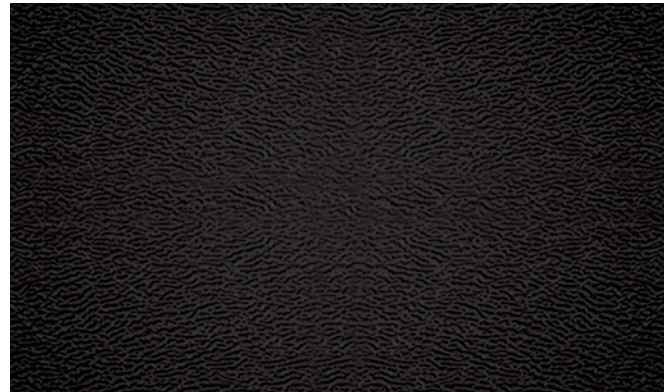

BLACK

### WHEEL OPTIONS

**Model 1616**  
*5" Gray wheel*



**Model 1618**  
*5" Special Gray wheel*



**Model 1625**  
*6" Gray wheel*



**Model 1626**  
*6" Cushion Gray wheel*



**Model 1632**  
*8" Black wheel*



**Model 1634**  
*8" Gray wheel*



**Model 1639**  
*8" MOR Gray wheel*



**Model 1641**  
*8" Cushion Gray wheel*



**Model 1635**  
*8" Black pneumatic wheel*



**Model 1681-S/1681-SDL**  
*6" Tracking caster w/ locking wheel*



# HOUSEKEEPING EQUIPMENT

## LAUNDRY, LINEN, & UTILITY CARTS

### LAUNDRY, LINEN, & UTILITY CARTS

Forbes offers a wide selection of quality Laundry and Linen carts to make housekeeping a breeze. They are available in several different sizes and designs, from sorting to bulk storage cabinets. Custom designs are available.



\*Folds for compact storage



#### Model 1128-EN

*Folding laundry cart*



*Textured black finish*

*Includes 4 bushel H.D. canvas bag #32-CV-E*

*Corner bumpers*

*4" all swivel Gray wheels*

	Length	Width	Height
in:	26.5	26	40.5
cm:	68	67	103

\*Folded dims: 11"L x 46"H



#### Model 1100-B

*1" round tube superstructure*

*1" reinforced square steel tube base*

*Includes 7 bushel H.D. cloth bag #22-CL-E*

*Finished in silver powder-epoxy paint*

*4" all swivel Gray wheels*

*Black vinyl bumper*

	Length	Width	Height
in:	24.5	24.5	34
cm:	63	63	86

\*Model 1100 - Non-bumpered version (23"D)



#### Model 1106-B

*1" steel tube frame*



*Silver powder-epoxy paint*

*Reinforced steel tube base*

*Includes 6 bushel H.D. cloth bag #23-CL-E*

*Black vinyl bumper*

*4" Gray wheels*

	Length	Width	Height
in:	23.75"	23.75	32.5
cm:	61	61	83

\*Model 1106 - Non-bumpered version



**Model 1112-B**

- 1" steel tube frame*
- Silver powder-epoxy paint*
- Reinforced steel tube base*
- Includes 12 bushel H.D. cloth bag #30-CL-E*
- Black vinyl bumper*
- 4" Gray wheels*

	Length	Width	Height
in:	38.5	23.5	37.5
cm:	98	60	96

\*Model 1112 - Non-bumpered version



**Model 1120-B**

- 1" steel tube frame*
- Silver powder-epoxy paint*
- Reinforced steel tube base*
- Includes 15 bushel H.D. cloth bag #31-CL-E*
- Black vinyl bumper*
- 5" Gray wheels*

	Length	Width	Height
in:	48.5	23.5	39
cm:	124	60	100

\*Model 1120 - Non-bumpered version



# HOUSEKEEPING EQUIPMENT

## LAUNDRY, LINEN, & UTILITY CARTS

### Optional accessory for poly tubs

Spring lift insert. Please call for more information.

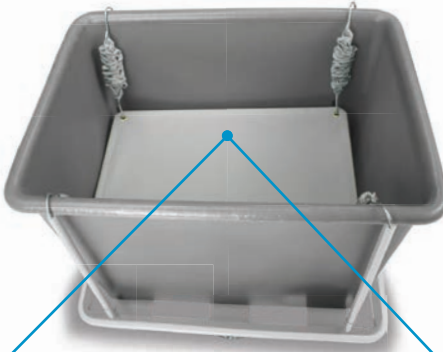

#### **Model 1179-B**

*H.D. polyurethane lift-out tub - 12 bushel*

*5" special Gray wheels*

	Length	Width	Height
in:	40	30	35
cm:	102	77	89

\*Model 1179 - Non-bumpered version



#### **Model 1181-B**

*H.D. polyurethane lift-out tub - 16 bushel*

*5" special Gray wheels*

	Length	Width	Height
in:	44	32	36
cm:	112	82	92

\*Model 1181 - Non-bumpered version



### Model 1228-MEBD

*Cabinet size: 48"L x 24"W x 60"H*

*Three shelves*

*Steel mesh ends, back panels and locking doors*

*Reinforced steel base*

*Silver powder-epoxy finish*

*Full wrap-around vinyl bumper*

*6" Gray wheels (two swivel and two rigid)*

	Length	Width	Height
in:	52	28.5	68.5
cm:	133	73	174

*\*Model 1228 - Frame and shelves only*

*\*Model 1228-ME - Mesh end panels only*

*\*Model 1228-MEB - Mesh ends and back panel*

### Model 1228-SEBD

*Cabinet size: 48"L x 24"W x 60"H*

*Three shelves*

*Solid ends, back panels and locking doors*

*Reinforced steel base*

*Silver powder-epoxy finish*

*Full wrap-around vinyl bumper*

*6" Gray wheels (two swivel and two rigid)*

	Length	Width	Height
in:	52	28.5	68.5
cm:	133	73	174

*\*Model 1228-SE - Solid end panels only*

*\*Model 1228-SEB - Solid ends and back panel*

# HOUSEKEEPING EQUIPMENT

## GARMENT RACKS

### GARMENT RACKS

Forbes Garment Racks are designed to maximize efficiency with minimal effort. They are offered in a variety of sizes and finishes to suit your needs. Custom designs are available.



#### Model 2409

*1" diameter stainless steel superstructure*

*Five-shelf cabinet, open on each side*

*Carpeted deck*

*Full wrap-around vinyl bumper*

*8" Gray wheels*

	Length	Width	Height
in:	47	22	70.5
cm:	120	56	180



#### Model 991

*1" diameter stainless steel tube*



*3" Gray wheels (all swivel)*

	Length	Width	Height
in:	42	21.5	70
cm:	107	55	178



**Model 996**

*1.25" diameter steel tube (painted)*

*Stainless steel top rail*

*Hat rack (painted)*

*3" Gray wheels (all swivel)*

	Length	Width	Height
in:	60	21.5	71
cm:	153	55	181

**Model 998**

*1.25" Diameter painted steel tube*

*Four stainless steel top rails*

*5" Gray wheels (all swivel)*

	Length	Width	Height
in:	60	25	70
cm:	153	64	178



# Luggage Racks

STEEL | WOOD

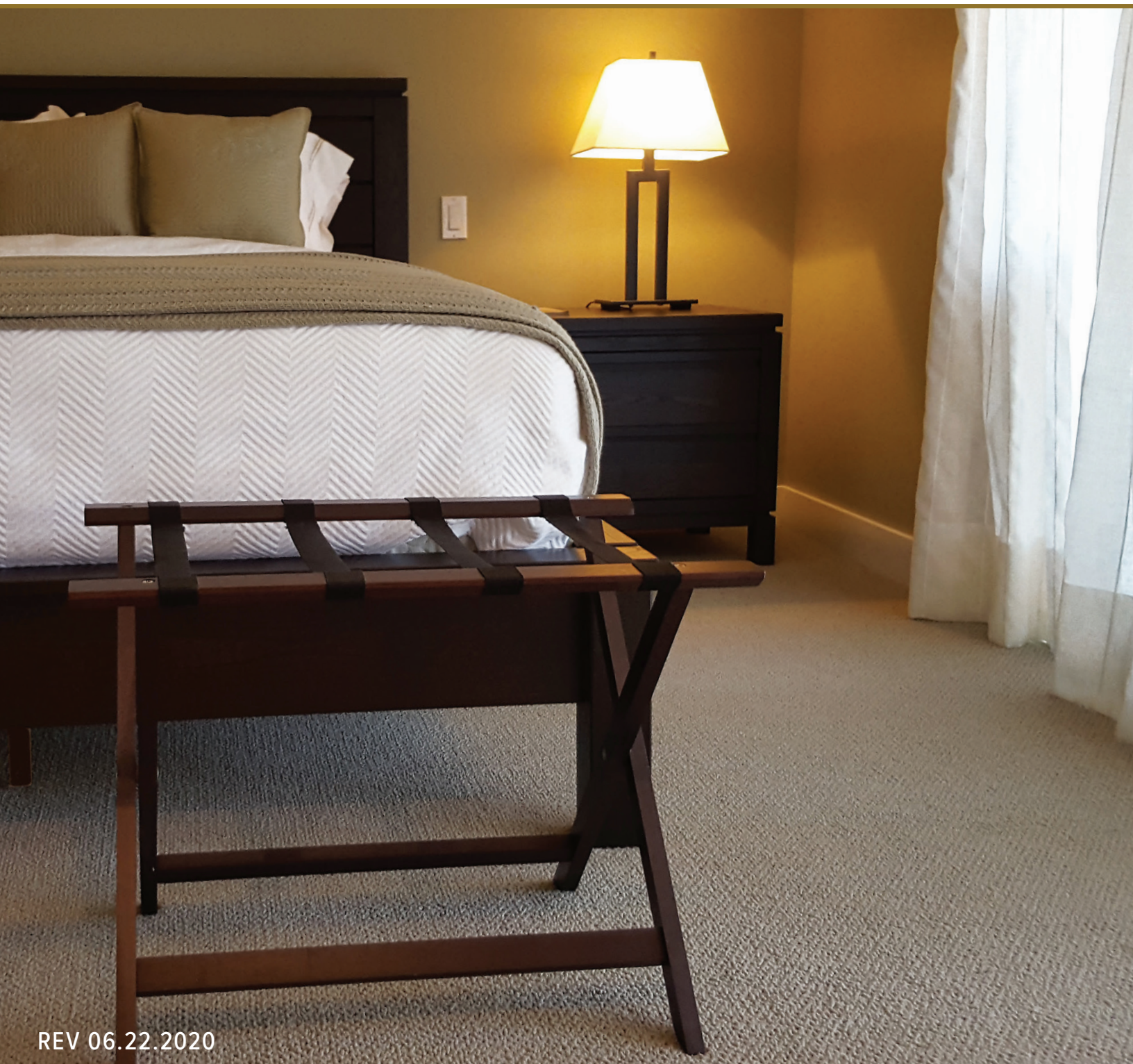



# LUGGAGE RACKS

## LUGGAGE RACKS

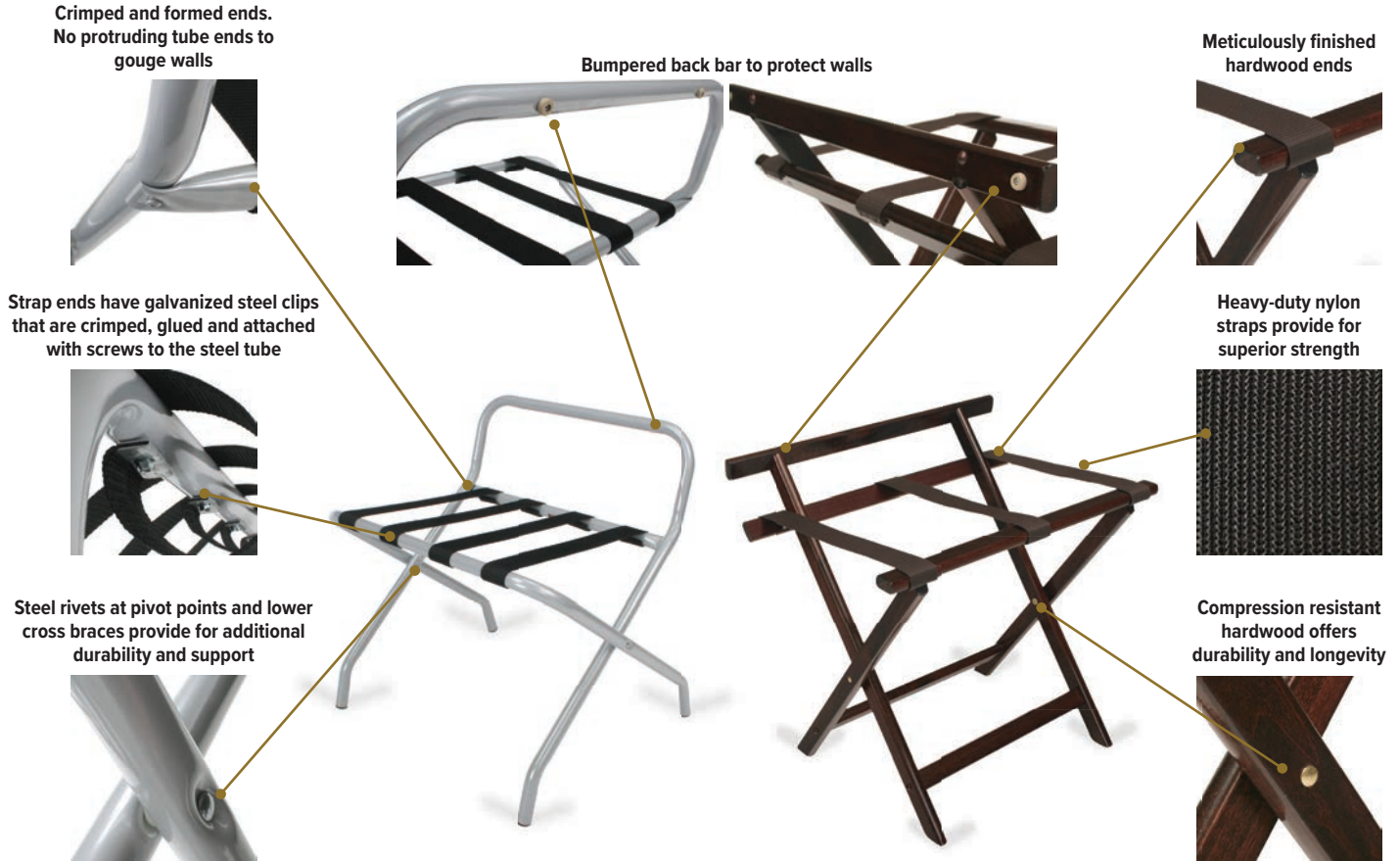

## WOOD OPTIONS

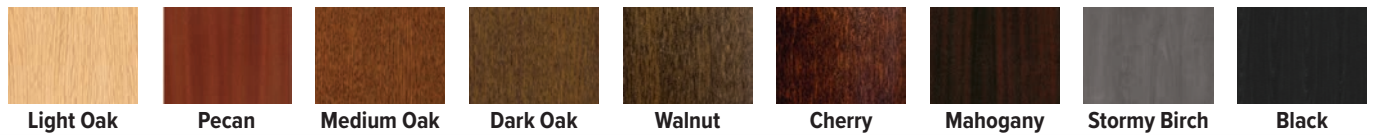

## TUBE OPTIONS



## STRAP OPTIONS

### Standard Strap Colors

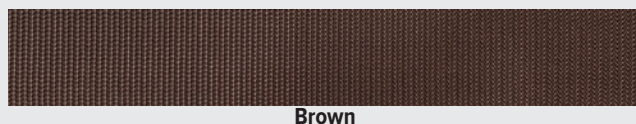

### Upgraded Strap Colors

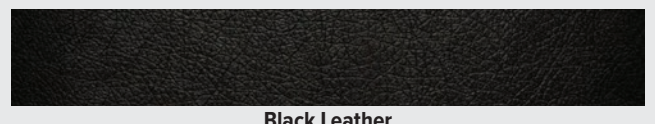
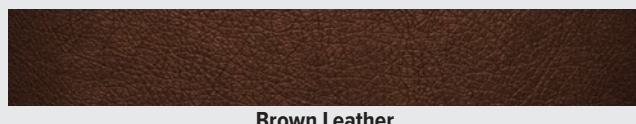

# LUGGAGE RACKS

## STEEL LUGGAGE RACKS

### STEEL LUGGAGE RACKS

Constructed of durable steel or tube, these racks are offered in several sizes, with or without bumpered back bar, and are available in six standard finishes. Stainless steel models come standard with a brushed finish.



#### Model 800

*Steel luggage rack*



*Round tube design*

*Bumpered back bar*

	Depth	Width	Height
in:	21	24	24,5
cm:	54	61	63

#### Model 801

*Steel luggage rack*

*Round tube design*

	Depth	Width	Height
in:	18	24	20,5
cm:	46	61	53



**Model 804-EN**

*Steel luggage rack*

*Rectangular /Square tube combo design*

*Black powder-epoxy finish*

	Depth	Width	Height
in:	24.5	16	21
cm:	62	41	54



**Model 804-SS**

*Stainless Steel luggage rack*

*Rectangular/Square tube combo design*

*Brushed stainless steel finish*

	Depth	Width	Height
in:	24.5	16	21
cm:	62	41	54



# LUGGAGE RACKS

## WOOD LUGGAGE RACKS

### WOOD LUGGAGE RACKS

Forbes wood luggage racks are available with straight or contoured legs and offer an upscale choice that accommodates a wide variety of decors.

**Compact design is  
great for boutique hotels!**



#### **Model 902**

*Hardwood luggage rack*

*Contoured leg design*

*Bumpered back bar*

	Depth	Width	Height
in:	20	24	26.5
cm:	51	61	68

#### **Model 932**

*Hardwood luggage rack*

*Straight leg design*

*Bumpered back bar*

	Depth	Width	Height
in:	17.75	24	23.75
cm:	45	61	61



#### **Model 931**

*Compact design for smaller areas*

*Hardwood luggage rack*

*Straight leg design*

*Bumpered back bar*

	Depth	Width	Height
in:	16.75	19.5	23.75
cm:	43	50	61

\*MOQ of 50 units

*Compact design is  
great for boutique hotels!*



### Model 904

*Hardwood luggage rack  
Contoured leg design*

	Depth	Width	Height
in:	19	24	22
cm:	49	61	56

### Model 934

*Hardwood luggage rack  
Straight leg design*

	Depth	Width	Height
in:	15.5	24	20.5
cm:	40	61	53

### Model 933

*Compact design for smaller areas  
Hardwood luggage rack  
Straight leg design*

	Depth	Width	Height
in:	15	19.5	21
cm:	38	50	54

\*MOQ of 50 units



# Host & Valet Stations

HOST & VALET STATIONS





**Model 5906**

*Clad in Satin Brown Mahogany stained hardwood  
 Black laminate base  
 One center shelf  
 Two wheels for tilt-and-roll maneuverability*

	Depth	Width	Height
in:	26	26.5	48
cm:	67	68	122



**Model 5941**

*Clad in Tropical Hardwood  
 Stainless steel cabinet  
 Avonite top and riser  
 Two stainless steel locking drawers  
 Two stainless steel locking doors  
 Four swivel casters (two with brakes)*

	Depth	Width	Height
in:	26	34.5	48.5
cm:	67	88	124

See the Tropical Hardwood family of products at [www.forbesindustries.com/tropicalhardwood](http://www.forbesindustries.com/tropicalhardwood)



# HOST & VALET STATIONS

## HOST & VALET STATIONS



### Model 5926

*Wood veneer finish*

*Avonite top and working surface*

*Solid wood molding*

*Two locking drawers*

*Two large storage areas with two locking doors*

*Adjustable furniture levelers*

	Depth	Width	Height
in:	28	51	46
cm:	72	130	117

### Model 5936

*Wood veneer finish*

*Avonite top and working surface*

*Solid wood molding*

*Two locking drawers*

*Locking bottom compartment*

*Adjustable furniture levelers*

	Depth	Width	Height
in:	26	41.5	47
cm:	67	106	120



**Model 4894**

- Laminate finish*
- Shown with stainless steel colored trim (brass is standard)*
- Two locking drawers*
- Locking bottom compartment*
- Adjustable furniture levelers*

	Depth	Width	Height
in:	22	34.5	44
cm:	56	88	112

\*Model 5924 - Wood veneer version with Avonite work surface  
 \*Brass accents also available - call for details

**Model 5937**

- Wood veneer finish*
- Three cubbies above working surface*
- Locking cash drawer*
- Open section in middle*
- Locking bottom compartment with two shelves*
- Four 5" wheels (two with brakes)*

	Depth	Width	Height
in:	32	36	50
cm:	82	92	127

# HOST & VALET STATIONS

## ACCESSORIES

### OPTIONAL ACCESSORIES



**Model 6060-19**  
*Flexible microphone holder*



**Model 8042**  
*Power strip*



**Model 8001**  
*Drop leaf*



**Model 6064**  
*Dual intensity light*



**Model 6065**  
*Gooseneck little light*



**Model 6066**  
*Gooseneck microphone with shock mount*



**Model 6075**  
*Digital clock & timer*



**Model 6072 Series**  
*Wireless microphones*



**Padded Nylon Cover**  
*Heavy-duty padded nylon covers with Velcro flaps*

### CUSTOM ACCESSORIES



**Sound System**  
*Sound system with 6064 light and 6066 microphone (6071 - wireless)*



**Pull Out Shelf**  
*Laminate or wood veneer pull-out shelf*



**Auto Height Control**  
*Auto height control adjusts up to 10" with the push of a button*



**Pull out Drawer**  
*Laminate or wood veneer drawer (locking option is available but not included)*

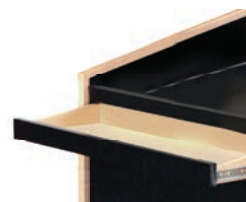

**Keyboard Drawer**  
*Pull-out keyboard drawer*

*\*Not all accessories are available on all models. Please call for details.*





Engraved with Black Painted Background  
Shown on brushed chrome



Engraved with Black Painted Background  
Shown on polished chrome



Silk Screen  
Available on polished brass,  
polished chrome or brushed  
chrome



Water Jet Cut  
Shown in brass



Water Jet Cut  
Shown in chrome

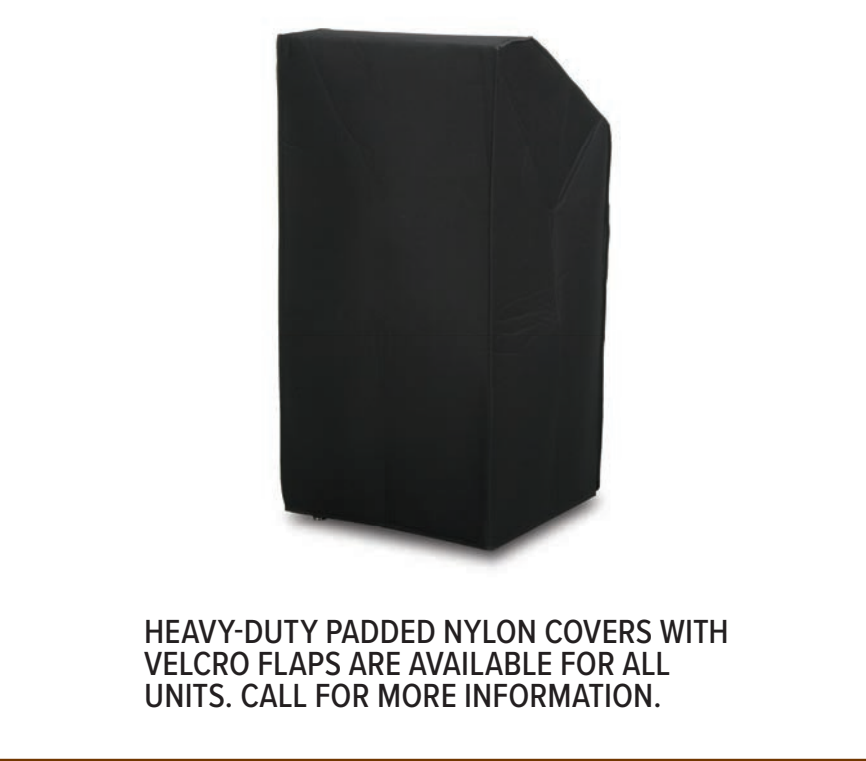

HEAVY-DUTY PADDED NYLON COVERS WITH  
VELCRO FLAPS ARE AVAILABLE FOR ALL  
UNITS. CALL FOR MORE INFORMATION.

CUSTOM LOGOS ARE AVAILABLE.  
PLEASE CALL FOR MORE INFORMATION.



Engraved with Black Painted Background  
Shown on polished brass



Laser Etched  
Available on clear acrylic

\*For a complete list of finish options, please visit: [www.forbesindustries.com/finish-options](http://www.forbesindustries.com/finish-options)

# CRAFTSMANSHIP

## Features, Advantages and Benefits

- Tons of styles to choose from to fit any decor
- Made from top of the line materials to ensure quality
- Many sizes are available to fit any operation
- Top quality hardware used throughout

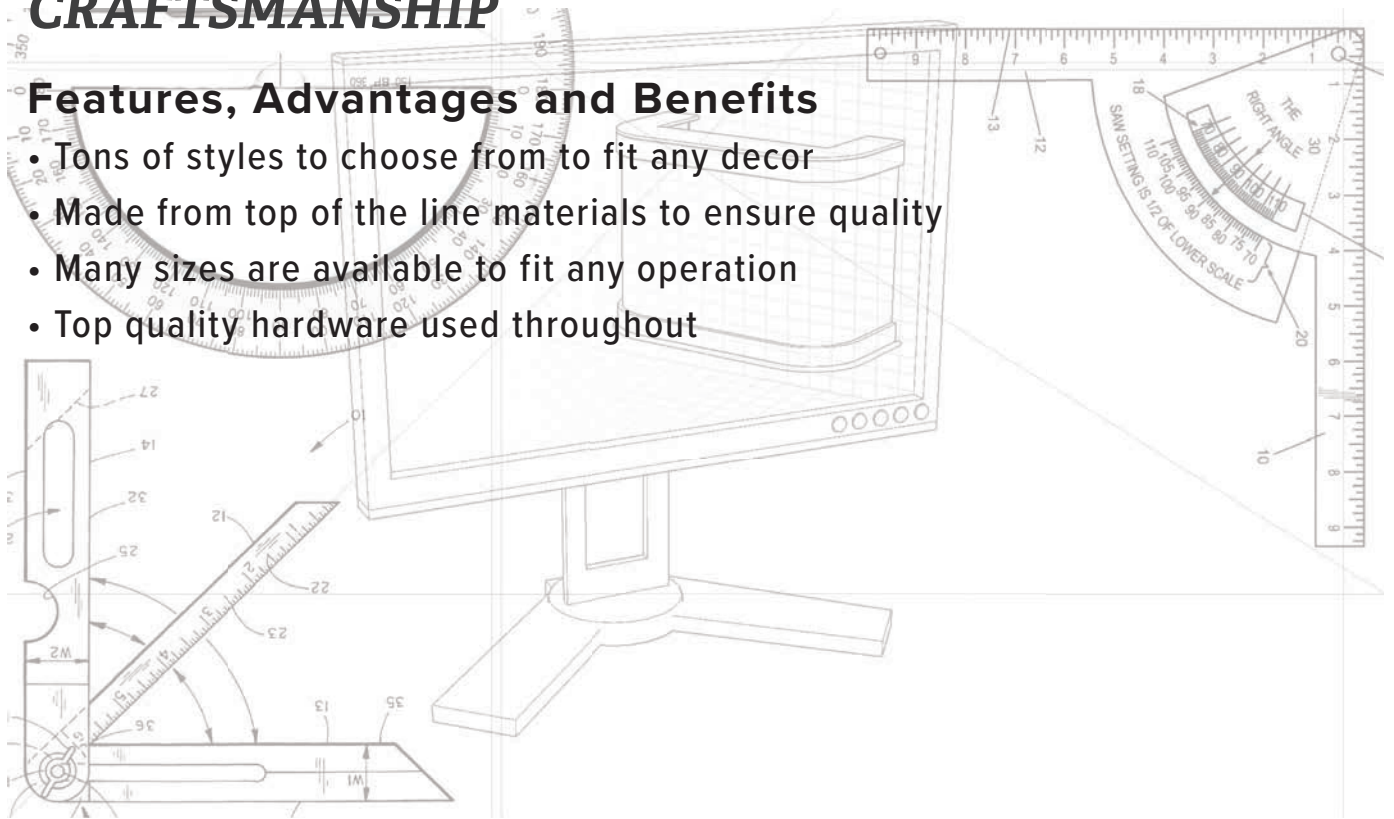

CRAFTSMANSHIP

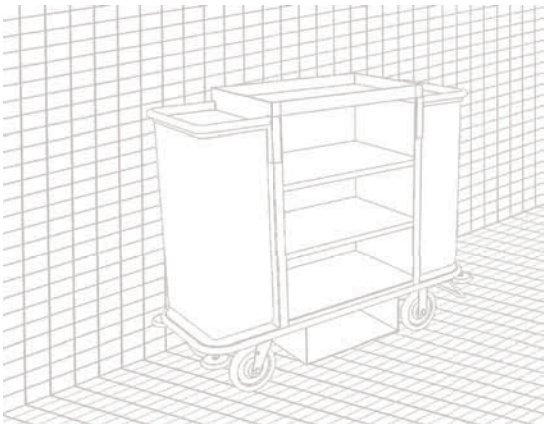



# Portable Dance Floors

FLORLOK | OUTLOK



# Features



INDOOR	✓	✓
OUTDOOR	✓	
BRICK WORK DESIGN	✓	✓
FRAME SUBSTRATE	ABS Plastic	Aluminum/Plywood
SURFACE	Vinyl/Acrylic	Hardwood
AVAILABLE FINISHES	Auckland Oak/Bracken/ Ebony Oak/ Distressed Oak/Vintage Pine/	Light Oak Parquet/ Smoked Oak Parquet/ Jatoba Parquet
TRIM (Natural Aluminum is standard. All other finishes are subject to up-charge.)	Natural Aluminum/ Black or Gold Anodized	Natural Aluminum/ Gold Anodized
TRIM SIZE	4"W	5"W
FULL PANEL SIZE	34" x 34"	34" x 34"
HALF PANEL SIZE	34" x 17"	34" x 17"
TRANSPORT CART AVAILABLE	Holds 15' x 15' Cart: 44" x 26" x 50" - 163lbs	Holds 15' x 15' Cart: 44" x 26" x 50" - 163lbs
MIN-MAX SIZE	6' x 6' - 48' x 48'	6' x 6' - 48' x 48'
NO TOOLS REQUIRED	✓	✓
WHEELCHAIR ACCESSIBLE	✓	✓
WIPE CLEAN SURFACE	✓	✓
3-YEAR WARRANTY	✓	✓
RIBBED BATTENS ON REAR OF PANELS		✓
LACQUERED PLYWOOD BASE		✓
WATERPROOF	✓	
PRESSURE WASH TOLERANT	✓	
ENVIRONMENTALLY FRIENDLY/RECYCLABLE	✓	



Built with durability and beauty in mind, Forbes' Portable Dance Floors stand up to heavy use while maintaining their original strength and luster. Our interlocking dance floor panels are available in a variety of sizes, finishes, and substrates depending on your needs. These portable dance floors are ideal for hotels, restaurants, clubs, caterers, convention centers, event organizers, venues, trade shows and weddings.

Learn more at: [www.forbesindustries.com/dancefloors](http://www.forbesindustries.com/dancefloors)

## FEATURES - BENEFITS

- Two unique styles are available to fit your needs - Outlok, Florlok
- No screws or tools required - quick and easy set up and tear down
- Innovative brickwork design offers strength and ensures that panel edges are fully secured
- Both styles are configured to both full and half panel sizes making them lightweight and easy to handle
- Most floors can be set up in approximately 10 minutes and removed in about 8 minutes
- Low-profile and sloped edging - wheelchair accessible
- Wipe-clean surface - very low maintenance and easy to clean
- Durable dance floor - long lasting for better return on investment (ROI)
- 3-Year warranty on manufacturing, labor and materials
- Specially engineered powder-coated transport/storage carts are available making setup and tear-down a breeze
- Each cart is specifically manufactured to fit through standard single width doorways

### Innovative Brickwork Design

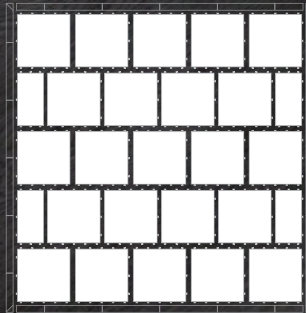

# PORTABLE DANCE FLOORS



## INDOOR USE

- Panels are manufactured with aluminum frames, ribbed battens and 7mm basket wood parquet
- Three different finishes top coated in a clear UV lacquer for extra protection
- No stain on the finish - same color throughout each piece of wood
- Comprised of two panel sizes, 34" x 34" (full panel) and 34" x 17" (half panel)
- Two trim color options to tie it all together
- Transport/storage carts are available for quick and effortless transport and storage
- Each cart holds a 15' x 15' complete dance floor (Cart: 44" x 26" x 50" - 163lbs)

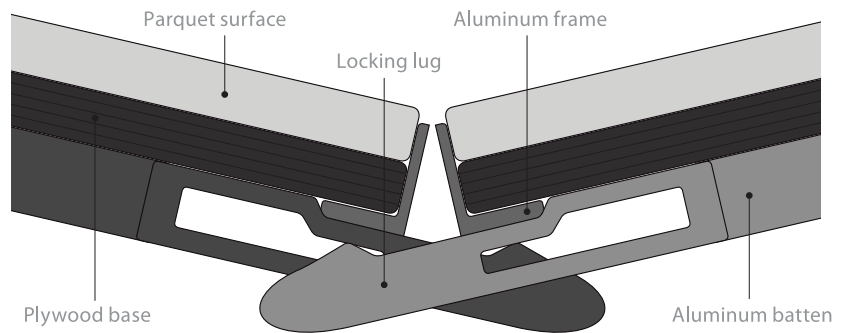

## FINISH OPTIONS



## TRIM OPTIONS - 5" AVAILABLE

Natural Aluminum is standard. All other finishes are subject to up-charge.

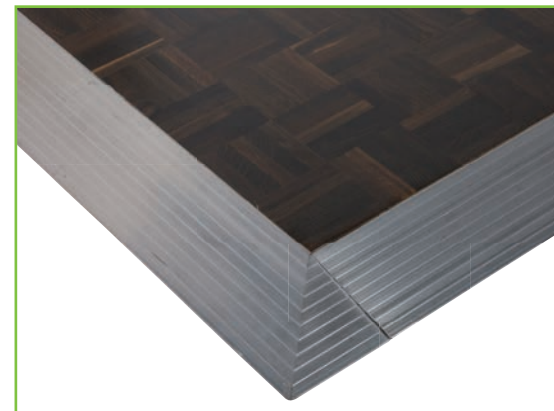
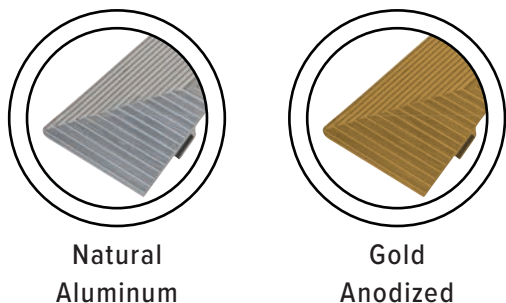





## OUTDOOR AND INDOOR USE

- Panels are manufactured using ABS plastic which offers strength and rigidity
- It is available with your choice of six different Karndean® commercial grade vinyl options
- Comprised of two panel sizes, 34" x 34" (full panel) and 34" x 17" (half panel)
- Structured rear panel - aids grip on carpets
- ABS plastic panel and inlay - 100% waterproof and recyclable
- Three trim options to tie it all together
- Transport/storage carts are available for quick and effortless transport and storage
- Each cart holds a 15' x 15' complete dance floor (Cart: 44" x 26" x 50" - 163lbs)

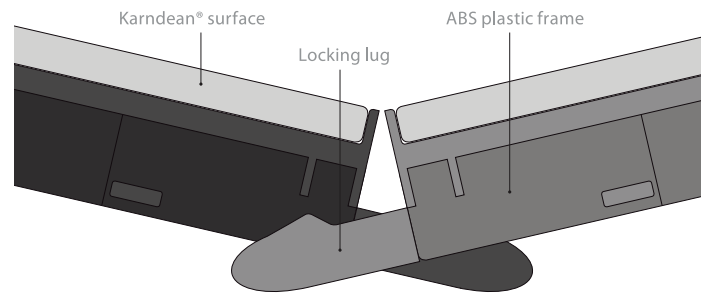

## FINISH OPTIONS



## TRIM OPTIONS- 4" AVAILABLE

Natural Aluminum is standard. All other finishes are subject to up-charge.

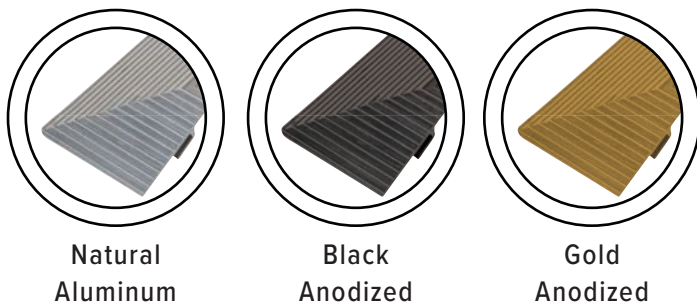



# ***Leading Manufacturer of Food & Beverage Products***

There is more to Forbes Industries than top-tier Hospitality products. Be sure to check out our full line of Food & Beverage products at: [www.forbesindustries.com](http://www.forbesindustries.com) or email: [sales@forbesindustries.com](mailto:sales@forbesindustries.com) to request a copy of our Food & Beverage catalog.



# Public Guidance Systems

CLASSIC STANCHIONS | RETRACTABLE BELTRAC STANCHIONS



REV 06.22.2020

# PUBLIC GUIDANCE

## CLASSIC STANCHIONS

### CLASSIC STANCHIONS

Forbes offers an extensive line of public guidance systems. With post choices in stainless steel and solid brass along with our various rope color and finial options you are assured of finding the right combination for your facility.



#### **Model 2746**

*Brushed brass  
Ball finial  
14" weighted flared base*

	Height
in:	40.75
cm:	104

\*Model 2744 - Brushed stainless steel  
\*Model 2745 - Polished stainless steel  
\*Model 2747 - Polished brass



#### **Model 2740**

*Brushed stainless steel  
Drum finial  
14" weighted flared base*

	Height
in:	39
cm:	100

\*Model 2741 - Polished stainless steel  
\*Model 2742 - Brushed brass  
\*Model 2743 - Polished brass

#### **Model 2735**

*Polished stainless steel  
Ball finial  
11" weighted bell base*

	Height
in:	40.75
cm:	104

\*Model 2734 - Brushed stainless steel  
\*Model 2736 - Brushed brass  
\*Model 2737 - Polished brass



# PUBLIC GUIDANCE

## CLASSIC STANCHIONS

### Velour Rope Options



EBONY VELOUR



CRIMSON VELOUR



SAPPHIRE VELOUR

### Vinyl Rope Options



GRAY VINYL



BLACK VINYL



RED VINYL

Snap Hook Finish	4' length	5' length	6' length	Snap Hook Finish	4' length	5' length	6' length
Brushed Stainless Steel	2784-4	2784-5	2784-6	Brushed Stainless Steel	2780-4	2780-5	2780-6
Polished Stainless Steel	2785-4	2785-5	2785-6	Polished Stainless Steel	2781-4	2781-5	2781-6
Polished Brass	2786-4	2786-5	2786-6	Polished Brass	2782-4	2782-5	2782-6



**Model 2738**  
*Painted Bronze finish*  
*Drum finial*  
*11" weighted bell base*

Height  
 in: 39  
 cm: 100

**Model 2723**  
*Polished brass*  
*Drum finial*  
*15" weighted flat base*

Height  
 in: 37.5  
 cm: 96

**Model 2725**  
*Polished stainless steel*  
*Ball finial*  
*15" weighted flat base*

Height  
 in: 37.5  
 cm: 96

\*Model 2730 - Brushed stainless steel  
 \*Model 2731 - Polished stainless steel  
 \*Model 2732 - Brushed brass  
 \*Model 2733 - Polished brass

\*Model 2720 - Brushed stainless steel  
 \*Model 2721 - Polished stainless steel

\*Model 2724 - Brushed stainless steel  
 \*Model 2727 - Polished brass

# PUBLIC GUIDANCE

## RETRACTABLE BELTRAC STANCHIONS

### RETRACTABLE BELTRAC SERIES

Forbes offers an extensive line of public guidance systems. With post choices in stainless steel, solid brass, chrome plated and textured black paint along with our various belt colors and accessories, you are assured of finding the right combination for your facility.

Beltrac® by Forbes



### VALUE PLUS SERIES

### DELUXE SERIES

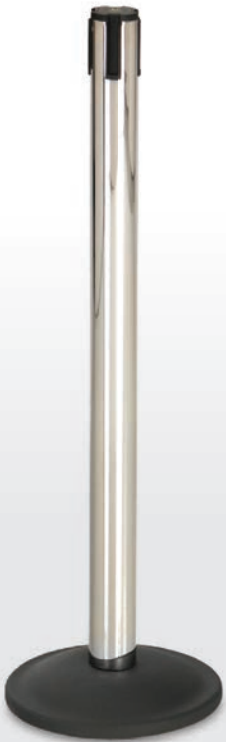

**Model 2701**  
*Chrome plated finish*  
*7 foot Beltrac*  
*12.5" weighted base*

	Height
in:	40
cm:	102



**Model 2700**  
*Textured black finish*  
*7 foot Beltrac*  
*12.5" weighted base*

	Height
in:	40
cm:	102

**Model 2712**  
*Polished stainless steel*  
*7 foot Beltrac*  
*14" weighted titanium base*

	Height
in:	40
cm:	102

**Model 2711**  
*Brushed stainless steel*  
*7 foot Beltrac*  
*14" weighted titanium base*

	Height
in:	40
cm:	102

# PUBLIC GUIDANCE

## RETRACTABLE BELTRAC STANCHIONS

### Sign Frames

Sign Frames available in gold, chrome, satin aluminum or black matte



**Model 2760 (Beltrac)**  
7" x 11" sign frame

\*Model 2761 for Drum top, classic



**Model 2762 (Beltrac)**  
11" x 14" sign frame

\*Model 2763 for Drum top, classic

### Belt Options

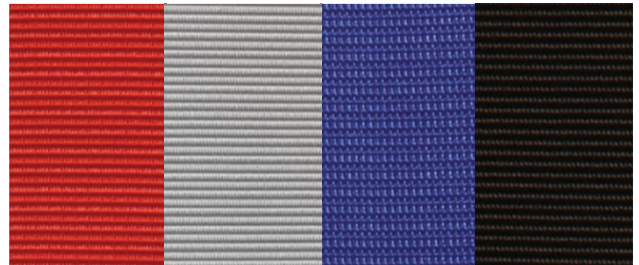

Red

Gray

Blue

Black

## PRESTIGE SERIES



### Model 2705

Chrome plated finish  
7' integrated Beltrac  
14" weighted base

	Height
in:	40
cm:	102



### Model 2704

Textured black finish  
7' integrated Beltrac  
14" weighted base

	Height
in:	40
cm:	102



### Model 2706

Gold anodized finish  
7' integrated Beltrac  
14" weighted base

	Height
in:	40
cm:	102

### Model 2799

Stanchion transport cart  
Steel superstructure  
Heavy duty non-marking wheels

	Length	Width	Height
in:	50	25	57
cm:	127	64	145



# Forbes Express Line

USUALLY SHIPS IN ONE WEEK OR LESS!



**FORBES EXPRESS LINE**

The Forbes Express Line of products are usually ready to ship within a week or less. We offer a variety of products for you to choose from, and all of them are backed by the quality and guarantee of Forbes' superior craftsmanship. When you need a product to fit your budget, and in a hurry, look to Forbes Express Line for all of your "quick-ship" solutions.



**Model 2421**

*2" Polished Brass tube*



*8" Black pneumatic wheels*

*Steel reinforced carpeted deck*



*Full wrap-around bumper*

	Length	Width	Height
in:	43	24	78
cm:	110	61	199



**Birdcage.**  
Cart



**Model 2426**

- 2" Polished Brass tube*
- 8" Gray cushion wheels*
- Steel reinforced carpeted deck*
- Full wrap-around bumper*
- Solid Brass skirt*

	Length	Width	Height
in:	43	24	78
cm:	110	61	199



**Model 2425**

- 2" Polished Brass tube*
- 8" Black pneumatic wheels*
- Steel reinforced carpeted deck*
- Full wrap-around bumper*
- Solid Brass skirt*

	Length	Width	Height
in:	43	24	78
cm:	110	61	199





**Birdcage**  
Cart



**Model 2428**

- 2" Polished Brass tube*
- 8" Black pneumatic wheels*
- Steel reinforced carpeted deck*
- Full wrap-around bumper*
- Solid Brass skirt*

	Length	Width	Height
in:	48	24	72
cm:	122	61	183



**Model 2528**

- 2" Polished Stainless Steel tube*
- 8" Black pneumatic wheels*
- Steel reinforced carpeted deck*
- Full wrap-around bumper*
- Stainless Steel skirt*

	Length	Width	Height
in:	48	24	72
cm:	122	61	183



**Birdcage.**  
Cart



**Model 2525**

*2" Polished Stainless Steel tube*

*8" Black pneumatic wheels*

*Steel reinforced carpeted deck*

*Full wrap-around bumper*

*Stainless Steel skirt*

	Length	Width	Height
in:	43	24	78
cm:	110	61	199



**Model 2521**

*2" Polished Stainless Steel tube*



*8" Black pneumatic wheels*



*Steel reinforced carpeted deck*

*Full wrap-around bumper*

	Length	Width	Height
in:	43	24	78
cm:	110	61	199



-  **Model 2434-RD-GY**  
*1" Silver powder-epoxy painted tube*
  -  *Red carpeted steel deck*  
*Full wrap-around gray bumper*
  -  *8" Black wheels*
- |     | Length | Width | Height |
|-----|--------|-------|--------|
| in: | 37     | 21    | 66.5   |
| cm: | 94     | 54    | 169    |

-  **Model 2495-RD-GY**  
*1" Brushed Stainless Steel tube*
  -  *Full wrap-around bumper*  
*8" Black wheels*
- |     | Length | Width | Height |
|-----|--------|-------|--------|
| in: | 47     | 22    | 70.5   |
| cm: | 120    | 56    | 180    |



THE  
*Mini-Rollen*  
 — HOUSEKEEPING —  
 CART

*durable - lightweight - elegant*



\*Divided caddy included



\*Model 2088-LB - Order Separately



**Model 2088**

*Large capacity storage section*

*Made with heavy duty nylon material*



*Retractable aluminum handle*

*Removable & stackable amenity caddy*



*Eight storage pockets*

*Reinforced sewn edges*



*Built-in literature storage*

*Four swivel wheels*

*Six-month warranty*

	Length	Width	Height
in:	20	16	28.75
cm:	51	41	73

\*Model 2088-LB - Optional collapsible laundry bag



After rumors were circulated that Forbes Industries' Housekeeping Carts were harder to push than a competitor's brand, an independent study was done to put the issue to rest. The study found that not only are Forbes' significantly easier to push, but they are also lighter and last longer than the leading competitor's carts.



**Model 2103**

*Cabinet size: 30"W x 19"D x 36"H*



*Low profile handles*

*Two shelves (one adjustable)*



*Vacuum bracket*

*Under-deck glass rack holder*

*Four revolving corner bumpers*

*One 20-NL-C long nylon bag (black) included*

*8" Black wheels*

	Length	Width	Height
in:	54.75	19	46.75
cm:	139	49	119

# INDEX



## Location photography courtesy of the following fine resorts:

The Ritz-Carlton New Orleans

Omni Rancho Las Palmas Resort & Spa

Andaz West Hollywood

Embassy Suites By Hilton Ontario Airport

NOPSI Hotel New Orleans Hotel

Woodlands Watterway Marriott

Springhills Suites Marriott Ontario Airport

Vista Collina Resort

Model	Page	Model	Page
18-CV	50	1179	63
18-NL	50	1179-B	63
19-CL	59	1181	63
19-NL	59	1181-B	63
19-NL-E	59	1228	64
20-CL	59	1228-ME	64
20-LS	59	1228-MEB	64
20-NL	41, 59	1228-MEBD	64
20-NL-E	59	1228-SE	64
21-CL	59	1228-SEB	64
21-NL	59	1228-SEBD	64
21-NL-E	59	1401	57
23-CL-E	61	1550-CK	31
26-E	49	1552-CK	31
30-CL-E	62	1555-B	33
31-CL-E	62	1555-B-PS	33
32-CV-E	61	1555-B-SS	33
34-B	59	1555-CK	32
34-E	59	1555-CK-PS	32
34-T	59	1555-CK-SS	32
35-E	59	1566-CK	32
35-T	59	1566-CK-PS	32
36-E	59	1566-CK-SS	32
36-T	59	1570-B	33
42-E	59	1570-B-PS	33
42-T	59	1570-B-SS	33
43-E	59	1570-CK	31
43-T	59	1570-CK-PS	31
46-BN	59	1570-CK-SS	31
46-E	59	1573	30
50-NL-E	52	1573-DECK	30
51-NL-E	52	1573-HB	30
240	25	1573-SS	30
250	25	1573-SS-HB	30
800	69	1574	28
801	69	1574-BSKT	29
804-EN	70	1574-HB	28
804-SS	70	1574-SS-HB	28
902	71	1575	28
904	72	1575-BSKT	29
931	71	1575-HB	28
932	71	1575-SS	28
933	72	1575-SS-HB	28
934	72	1603-BE	58
991	65	1603-GY	58
996	66	1616	60
998	66	1616-R	26
1100	61	1616-S	26
1100-B	61	1616-S/BK	26
1106	61	1618	60
1106-B	61	1625	60
1112	62	1626	60
1112-B	62	1626-R	26
1120	62	1626-RB	26
1120-B	62	1626-RC	26
1128-EN	61	1626-S	26



Model	Page	Model	Page	Model	Page
1626-SB	26	Retired Model.....Suggested Replacement/pg		Retired Model.....Suggested Replacement/pg	
1626-SB/BKB	26	2087	46	2331-B	57
1626-S/BK	26	2088	46, 97	2334	58
1626-SC	26	2088-LB	46, 97	2334-P	58
1626-SC/BKC	26	2101	38	2336	57
1626-W	26	2103	41, 98	2336-P	57
1632	60	2104	39	2337	50, 58
1632-R	26	2105	39	2338	50
1632-S	26	2106	2104 pg 39	2339	50
1632-S/BK	26	2107	38	2351	58
1632-W	26	2109	2161 pg 47	2351-P	58
1634	60	2110	40	2352	57
1634-R	26	2120	36	2353	58
1634-S	26	2140	40	2353-P	58
1634-S/BK	26	2141	40	2355	57
1634-W	26	2148	38	2356	58
1635	60	2150	39	2356-P	58
1635-R	26	2152	2200-38 pg 37/2105 pg 39	2357	57
1635-RB	26	2154	N/A	2360	58
1635-RC	26	2162	2120 pg 36	2360-M	58
1635-S	26	2191	2271 pg 47	2366	57
1635-SB	26	2192-30	2193-36 pg 37	2400-4Shelf	25
1635-SB/BKB	26	2192-36	36	2400-HCVR	25
1635-S/BK	26	2193-36	37	2400-Shelf	25
1635-SC	26	2197	2200-38 pg 37	2400-VCVR	25
1635-SC/BKC	26	2200-38	37	2409	65
1635-W	26	2200-42	2200-38 pg 37	2410	15
1635-WB	26	2201	2271 pg 47	2418	10
1635-WC	26	2208	N/A	2419	9
1636-R	26	2220	36	2421	10, 92
1636-RB	26	2238	48	2423	9
1636-RC	26	2244	48	2425	8, 93
1636-S	26	2261	47	2426	93
1636-SB	26	2262	2261 pg 47	2428	9, 94
1636-SC	26	2264	2261 pg 47	2431	21
1636-W	26	2265	47	2434	23
1636-WB	26	2271	47	2434-RD-GY	96
1636-WC	26	2272	2271 pg 47	2443	18
1639	60	2274	2275 pg 47	2479	MOQ 5 Units 19
1641	60	2275	47	2484	18
1641-R	26	2277	52	2486	2487 pg 19
1641-RB	26	2279	52	2487	19
1641-RC	26	2280	54	2495	22
1641-S	26	2281	56	2495-RD-GY	96
1641-SB	26	2291	2275 pg 47	2497	22
1641-SB/BKB	26	2320	57	2499	17
1641-S/BK	26	2320-B	57	2499-DT	17
1641-SC	26	2321	57	2505DB	14
1641-SC/BKC	26	2322	57	2505DB-SS	14
1641-W	26	2323	57	2510	15
1681-S	60	2324	57	2510-DT	15
1681-SDL	60	2324-2000	50	2510-PDT	15
2000-8	50	2325	57	2510-SS	15
2000-10	50	2326	57	2511-SS	16
2010	49	2327	57	2512-SS	16
2044	45	2329	57	2518	10
		2330	57	2518-DT	10

# RETIRED MODEL/SUGGESTED REPLACEMENT LIST

Model	Page	Model	Page	Model	Page
2518-PDT	10	2736	87	Retired Model.....Suggested Replacement/pg	
2518-SS	10	2737	87	8042	77
2519	9	2738	88		
2519-DT	9	2740	87		
2519-PDT	9	2741	87	H1211-5	H1211-5C pg 23
2519-SS	9	2742	87	H1211-5C	23
2521	10, 95	2743	87	H1211-8	H1211-8C pg 23
2521-DT	10	2744	87	H1211-8C	23
2521-PDT	10	2745	87		
2521-SS	10	2746	87		
2523	9	2747	87		
2523-DT	9	2760	90		
2523-PDT	9	2761	90		
2523-SS	9	2762	90		
2525	95	2763	90		
2525-CEN-EN-EN	7	2780-4	88		
2525-ECH-EN-EN	7	2780-5	88		
2526-SS	8	2780-6	88		
2528	9, 94	2781-4	88		
2528-DT	9	2781-5	88		
2528-PDT	9	2781-6	88		
2528-SS	9	2782-4	88		
2537	10	2782-5	88		
2537-DT	10	2782-6	88		
2537-PDT	10	2784-4	88		
2537-SS	10	2784-5	88		
2543	18	2784-6	88		
2543-DT	18	2785-4	88		
2543-PDT	18	2785-5	88		
2543-SS	18	2785-6	88		
2545DB	14	2786-4	88		
2545DB-SS	14	2786-5	88		
2549	17	2786-6	88		
2581	15	2799	90		
2581-SS	15	4894	76		
2700	89	5906	74		
2701	89	5924	76		
2704	90	5926	75		
2705	90	5936	75		
2706	90	5937	76		
2711	89	5941	74		
2712	89	6050-R	26		
2720	88	6050-RC	26		
2721	88	6050-S	26		
2723	88	6050-S/BK	26		
2724	88	6050-SC	26		
2725	88	6050-SC/BKC	26		
2727	88	6060-19	77		
2730	88	6064	77		
2731	88	6065	77		
2732	88	6066	77		
2733	88	6072	77		
2734	87	6075	77		
2735	87	8001	77		



## Established 1919

Forbes Industries is a U.S. based manufacturer with over 100 years of experience in the design and manufacturing of mobile carts and static products. All products are manufactured in our state-of-the-art facility in California and ship worldwide. We apply our core values to every product produced: Engineered with safety, durability, functionality and attractive appearance.

A leading manufacturer of Hospitality and Food & Beverage Products, Forbes stands by a philosophy that blends an uncompromising commitment to quality and excellence with a dedication to technological advancement and innovation.

Hospitality product range includes Luggage & Housekeeping Carts, Linen and Laundry Carts, Janitorial Carts, Luggage Racks, Action Stations, Nesting Tables, Rolling Displays, Mobile Partitions, Buffet Systems, Podiums, Mobile Bars, In-Room Dining Tables & Hot Boxes, Signage, Service Carts, Public Guidance Systems, Cooking Carts, Induction Tables, Tray Stands, Easels and Flip Charts, Dance Floors and Staging.

Forbes utilizes high quality materials such as steel, stainless steel, plastic, wood, brass, acrylic and glass, incorporating quality & value through innovative techniques in every model.





**HOSPITALITY SOLUTIONS | VOLUME III**

[www.forbesindustries.com](http://www.forbesindustries.com) | [sales@forbesindustries.com](mailto:sales@forbesindustries.com)

1933 East Locust Street | Ontario, California 91761

Phone: 800.832.5427 | Fax: 909.923.1969

We reserve the right to change and improve our products.

Join us on social media for special  
sneak-peaks and exclusive promotions!



© Forbes Industries 2019

REV 06.22.2020